

DIY Dining Table Bench

Copyright © 2014 Shanty-2-Chic.com

Supply List

Item	Quantity	Description
1 x 6 x 8'	2	Pine or whitewood board
2 x 4 x 8'	3	Pine or whitewood board
2 x 3 x 4'	1	Pine or whitewood board
4 x 4 x 8'	1	
1 x 4 x 4'	1	Optional, you can also use the 1 x 6 cutoffs for this
Brad nails	handful	
1-1/4" pocket hole screws	25	
2-1/2" pocket hole screws	30	
Wood glue and finish of choice		

Drill pocket holes as indicated by the arrows. All pocket holes in the 1 x 6 material are for 1-1/4" screws. The remainder of the pocket holes should be for 2-1/2" screws

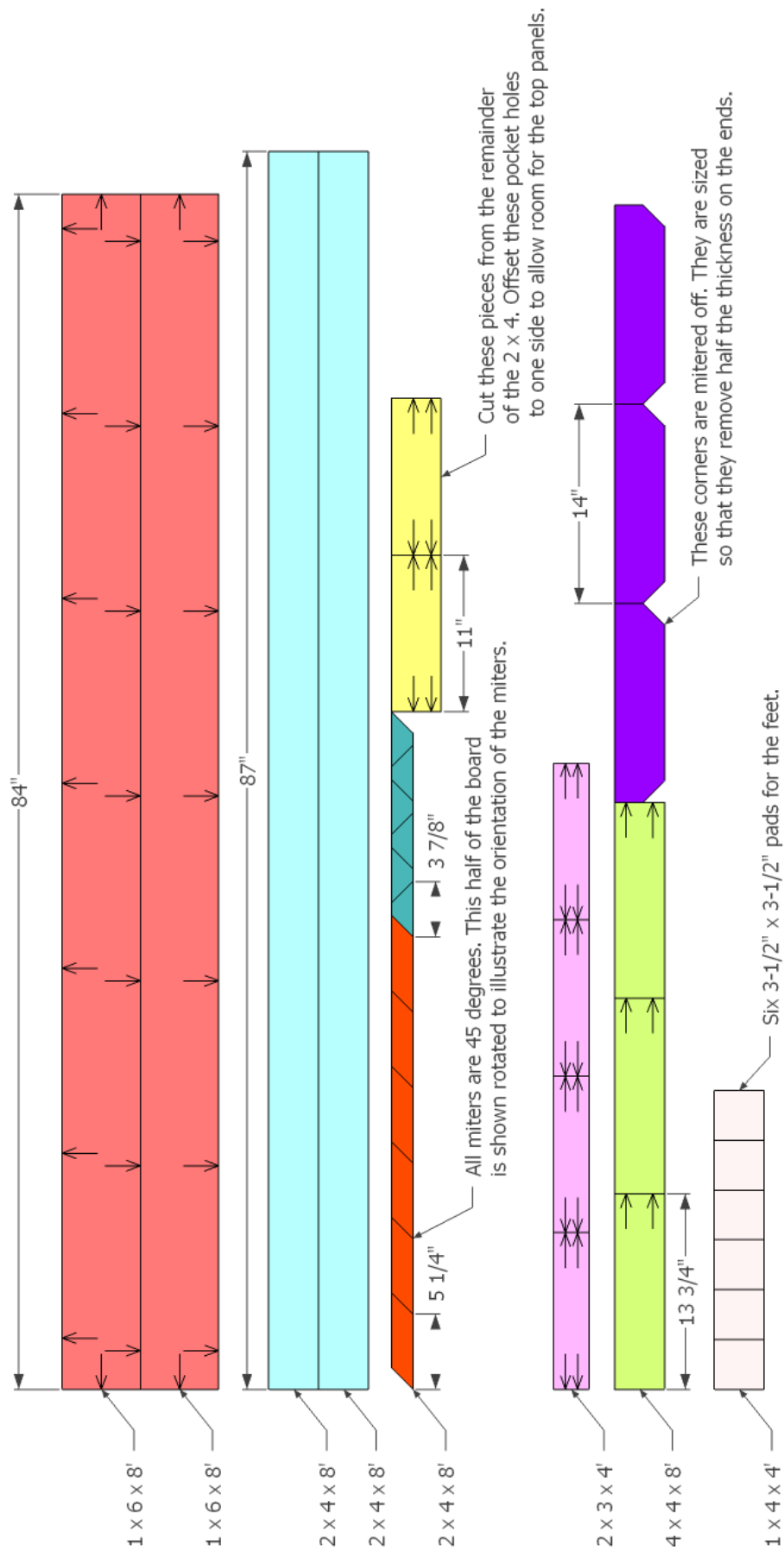

1

Assemble the top panel and it's frame. The panel is built with 1-1/4" pocket hole screws. The frame uses 2-1/2" pocket hole screws. Remember to use glue at every joint in this project.

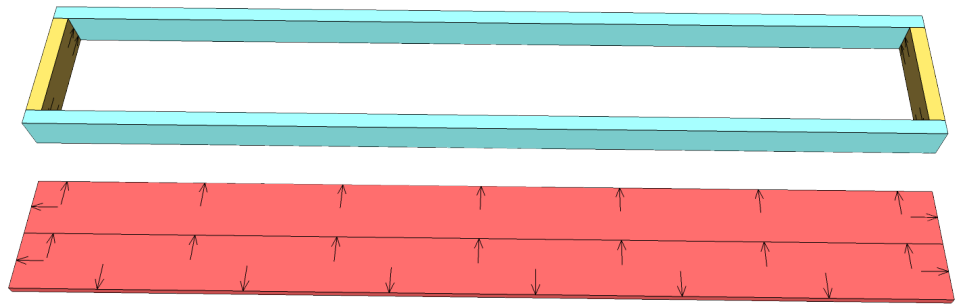

2

Put the panel in the frame and secure it with 1-1/4" pocket hole screws.

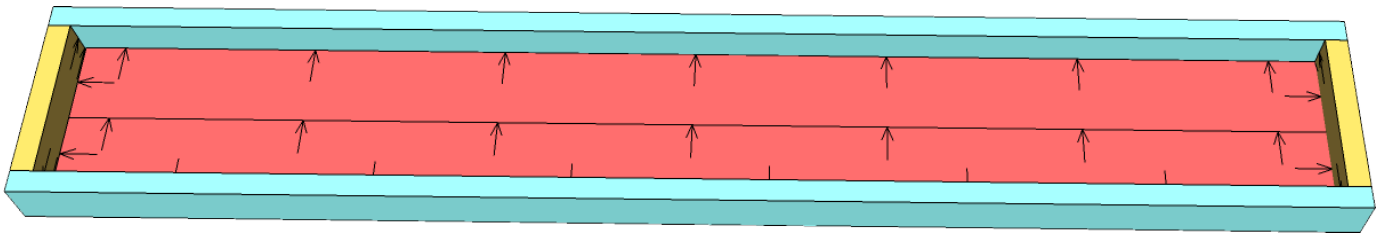

3

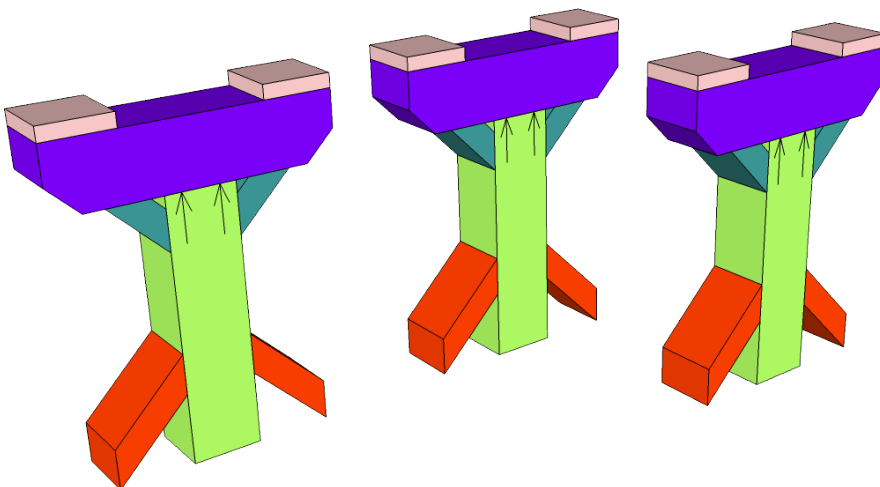

Assemble the legs. This may look like a lot but I promise it's super easy! Start by screwing the 4 x 4 pieces together with 2-1/2" pocket hole screws. Then add your smaller corner brackets with glue and 3" wood screws (pre-drill to prevent splitting!). Add your longer angled braces with screws as well. Finally glue and secure the foot pads with either screws or brad nails. Make sure these are below the surface of the wood or you will scratch your floor!

4

insert the end legs into the top with the pocket holes facing inward. Use lots of glue here! Next add a 2 x 3 brace and secure it to the bench sides with 2-1/2" pocket hole screws. Then screw through the brace into both the 4 x 4 as well as each 2 x 4 angled brace.

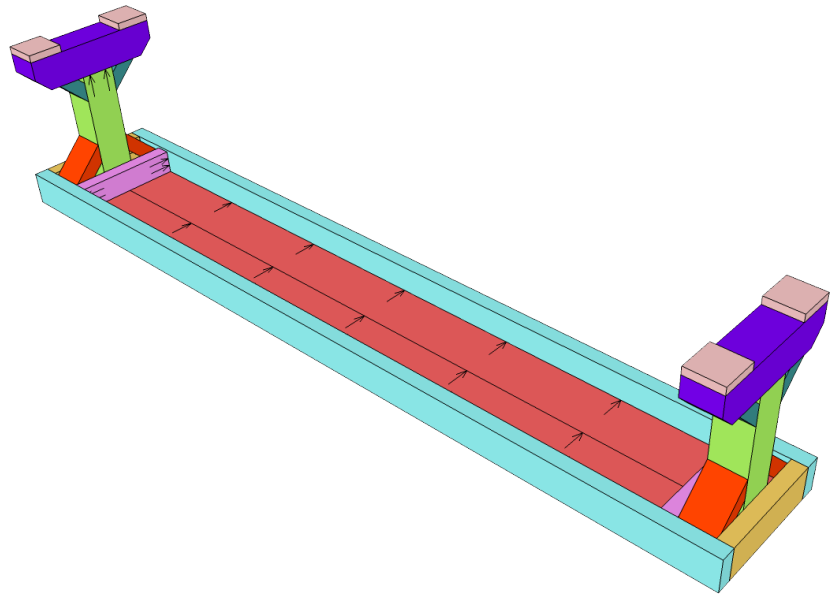

5

Do the same thing with the center leg. This time two 2 x 3 braces will be used though. One on each side. Remember to use lots of wood glue at every joint here. This will greatly increase strength.

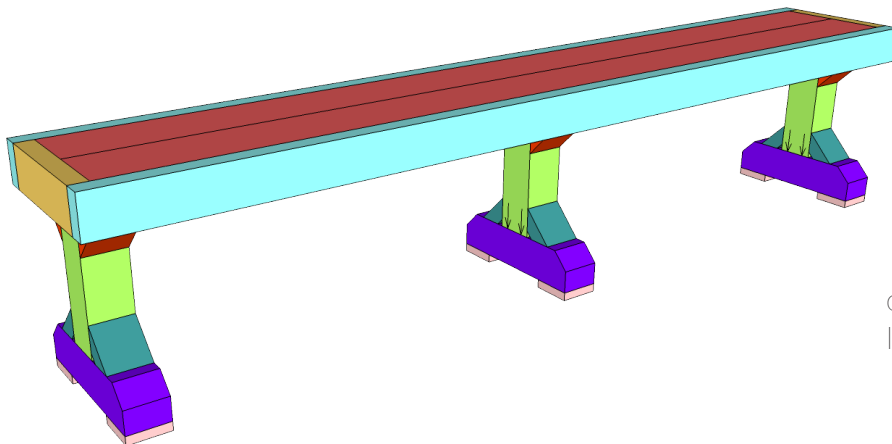
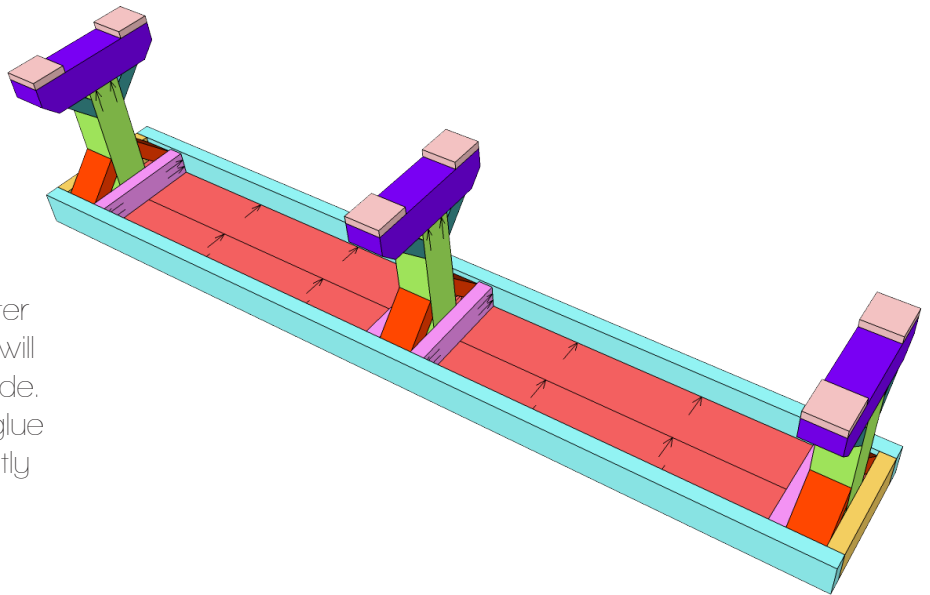

6

Quick Tip! Leave the bench upside down for about an hour after gluing the legs. This will allow enough time for any excess glue to harden so it won't drip down the legs when you flip it over.

Sand, finish, and ENJOY!