

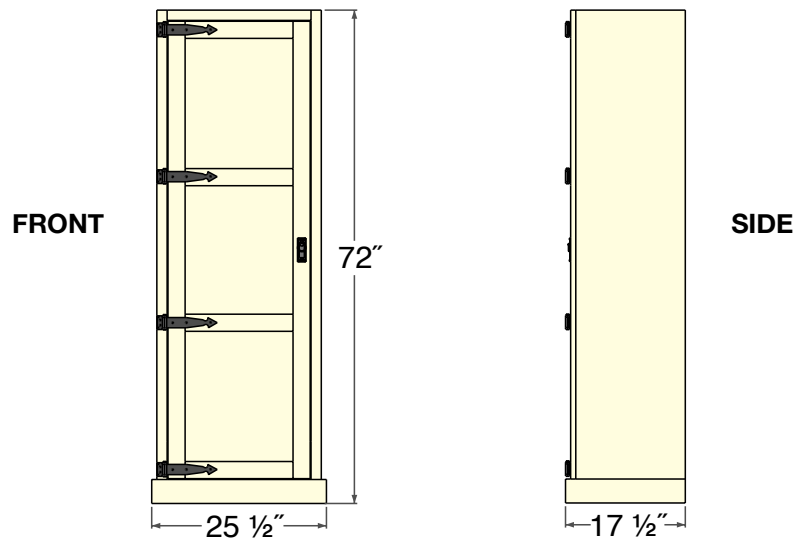

Entryway Locker

*T*his old world entryway locker is loaded with possibilities. Two adjustable shelves allow you to customize the storage to fit your needs. Even better, build as many as you need and attach them together for a large built-in locker system. It feels at home in your mudroom or entryway or anywhere you need extra storage.



Make sure you read through the instructions carefully and take notice of any special construction notes prior to making any cuts. And always practice safe DIY'ing. Have fun!

CUT LIST

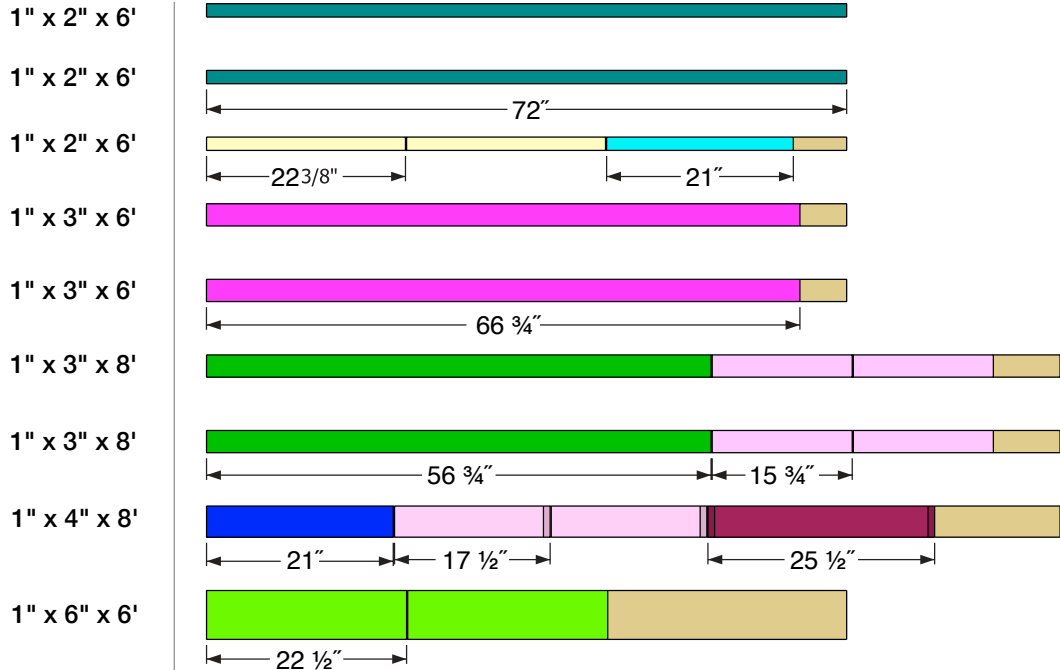

NOTE
For the mitered trim pieces you will want to cut them a little long to accommodate getting the right fit.

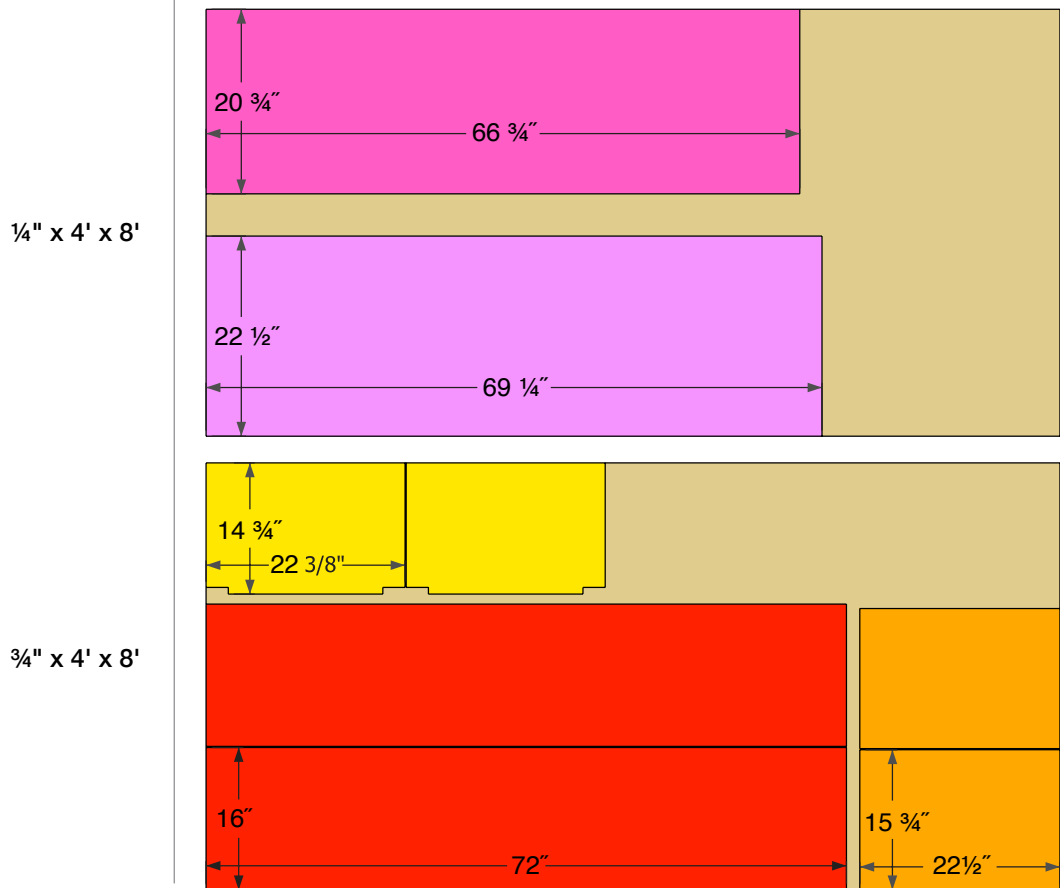

NOTE
See the next page for cutting diagram to have the store cut down your plywood into more manageable pieces.

PLYWOOD SHEET CUTTING GUIDE

Most stores that sell plywood offer you the ability to have full sheets of plywood roughly cut down to smaller, more manageable sizes. Here are simple diagrams to take with you that will help you instruct them to cut your sheets of plywood.

When you get home pay special attention to what sections yield what pieces.

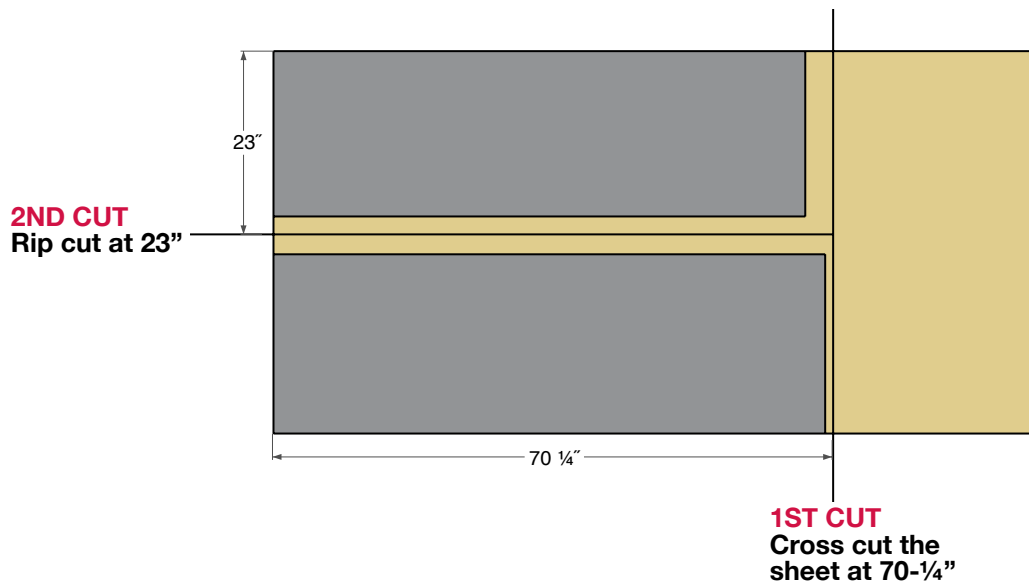
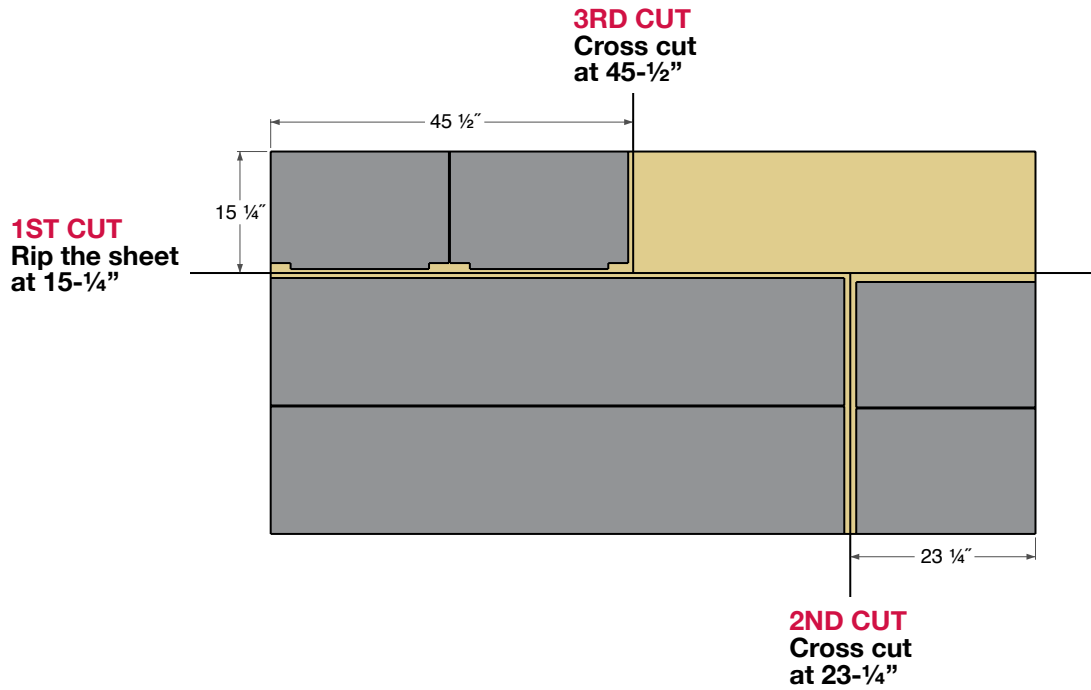

MATERIALS LIST

Material	Qty
¾" X 4' X 8' plywood	1
¼" x 4' x 8' plywood	1
1" x 6" x 6' pine board	1
1" x 4" x 8' pine board	1
1" x 3" x 6' pine board	2
1" x 3" x 8' pine board	2
1" x 2" x 6' pine board	3

Material	Qty
1-¼" pocket screws	
1-¼" brad nails	
¾" staples	
3" spax screws	2
¼" diameter shelf pins	8
wood glue	
hinges	3-4
door handle hardware	1

NOTES

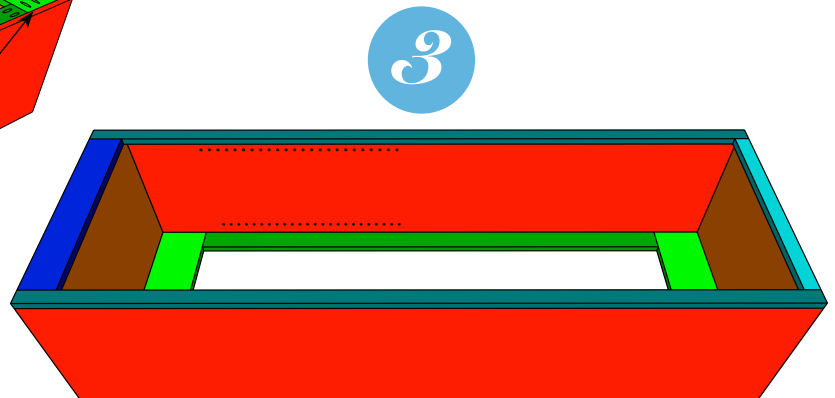
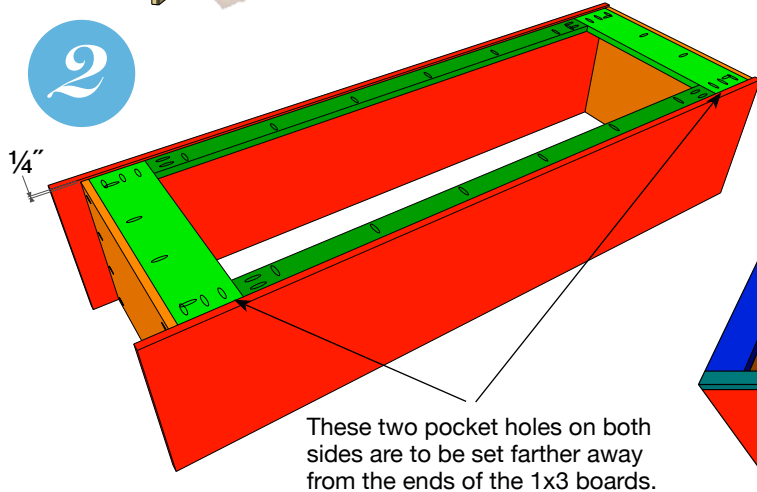
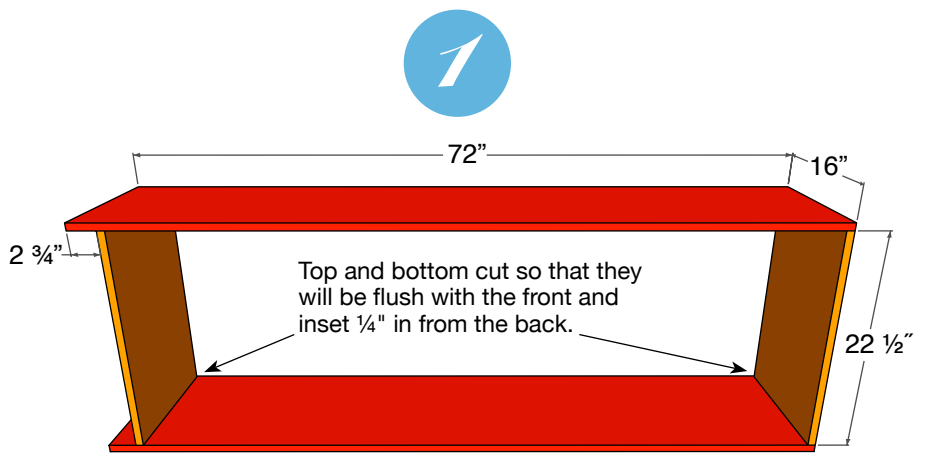
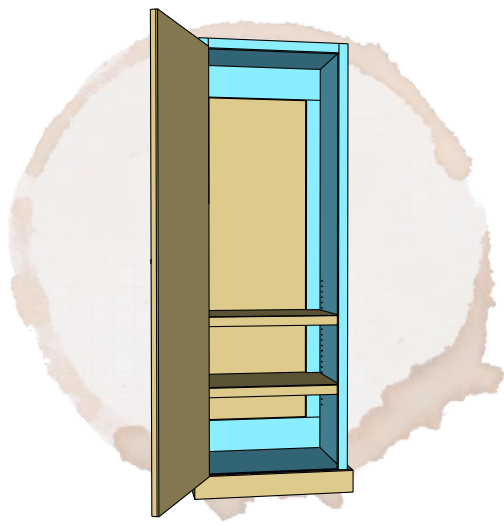

1.

Begin by attaching the top and bottom to the sides. Drill for 1- $\frac{1}{4}$ " pocket screws in the top and bottom panels. The top and bottom are sized so that they are inset $\frac{1}{4}$ " from the back edges. The top will be flush to the top and front edges of the side panels with the pocket screws facing up. The bottom will be inset 2- $\frac{3}{4}$ " from the bottom, as shown in the above illustration, and flush with the front edges of the side panels with the pocket holes facing down. Attach with screws and wood glue.

2.

Now we will attach the back bracing that will strengthen the locker and keep it from racking. Notice in the above illustration that all the back bracing is set $\frac{1}{4}$ " in from the back edge. First cut the horizontal 1x6 boards to length to fit snug within the side panels for both the top and bottom. Drill for 1- $\frac{1}{4}$ " pocket screws to go into the sides and the top or bottom as shown. The pocket holes in the 1x6 material that are near the 1x3 material in the next step will need to be down a little lower to accommodate the pocket screws in those 1x3 boards. Attach with screws and wood glue so that the boards are inset $\frac{1}{4}$ " from the back edge.

Cut the vertical 1x3 boards to length to fit snug between the just attached 1x6 boards. Drill for 1- $\frac{1}{4}$ " pocket screws to go into the sides and the top and bottom 1x6 boards as shown. Attach with screws and wood glue so that the boards are inset $\frac{1}{4}$ " from the back edge.

3.

Now flip the locker over to attach the face frame. Cut the vertical 1x2 boards to fit so that they are flush with the top and bottom. Attach with 1- $\frac{1}{4}$ " brads and wood glue. Now Cut the horizontal 1x2 boards to fit snug between the vertical 1x2s and attach with 1- $\frac{1}{4}$ " brad nails and wood glue.

To drill for the adjustable shelf pins we find the KREG shelf pin jig works wonders. Following the manufacturers instructions cut a piece of scrap wood so that when it is clamped to the inside of the locker, flush with the inside front corner behind the face frame and flush to the bottom, the KREG jig sits on the top edge of it and the first hole is about 8" from the bottom. Clamp the scrap wood in place. Remove the edge guide of the KREG jig so that it sits flush against the side panel, flush to the front inside corner and rests on the top edge of the scrap wood. Set the collar of the KREG drill bit to the appropriate depth. Drill your first hole. Push the locating pin in the first hole and then continue drilling the shelf pin holes. Remove the locating pin and move the jig up and place the locating pin through the first hole of the KREG jig and into the last hole you drilled in the side panel. Making sure the jig is again flush to the front inside corner, drill the remaining holes of the KREG jig. Continue this process until you have about 24 holes or about 30" up from the bottom. Flip the KREG jig and repeat this process for the back row of shelf pins. Now repeat for the opposite side.

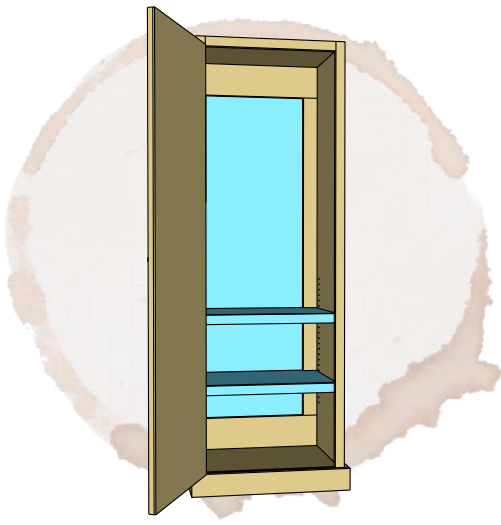

4

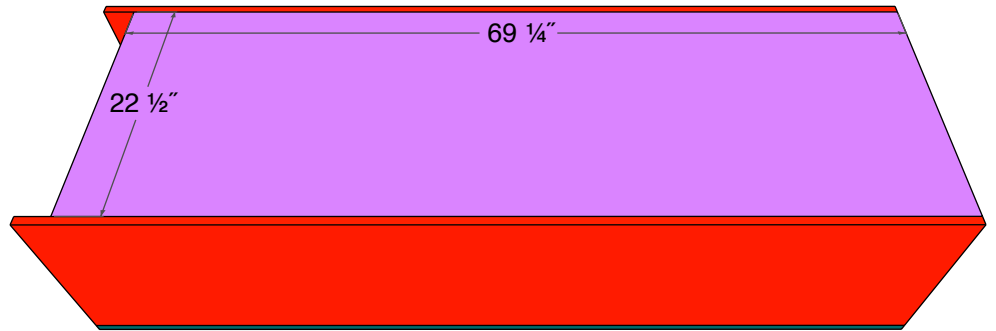

5

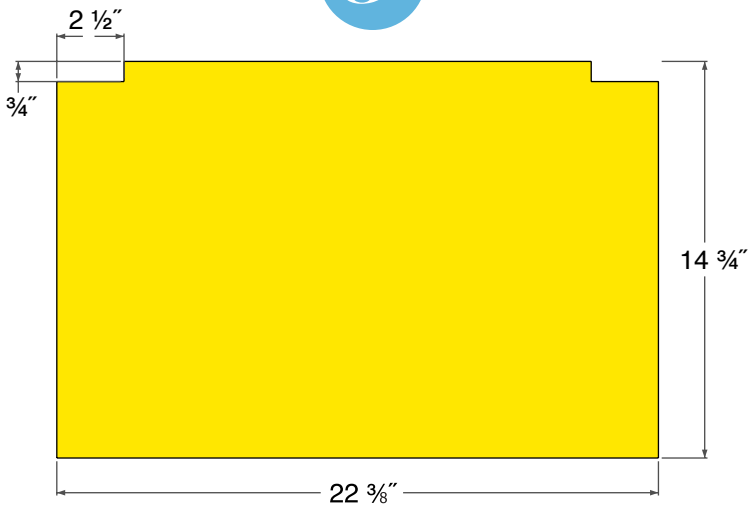

6

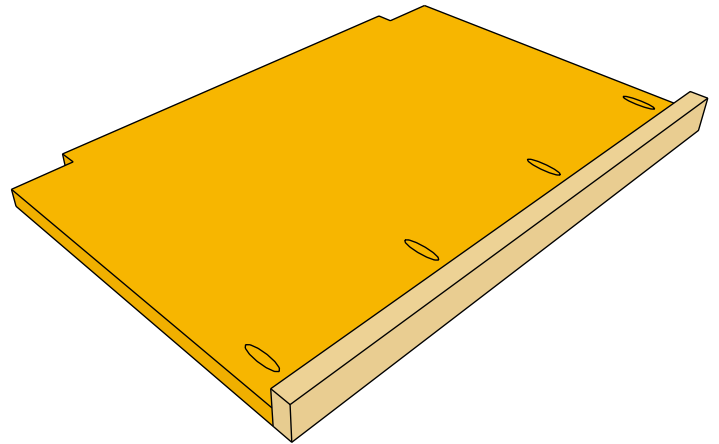

4.

Flip the locker back over so that the back is again facing up. The back bracing and top and bottom panels were inset $\frac{1}{4}$ " to accommodate the $\frac{1}{4}$ " plywood backing. Cut the plywood to fit snug inside the side panels and flush with the top and bottom. Attach with wood glue and $\frac{3}{4}$ " staples, they bite and hold $\frac{1}{4}$ " plywood better than brad nails. Brad nails and wood glue will work but just make sure to use enough glue.

5.

Time for the adjustable shelves. Notch the $\frac{3}{4}$ " plywood shelf panels as shown. These are to accommodate the back bracing when you install your shelves. You may want to make them slightly wider than $2\text{-}\frac{1}{2}$ " to accommodate for any swelling of the wood over time. Not much, just a hair wider.

6.

Drill for $1\text{-}\frac{1}{4}$ " pocket holes as shown and attach the shelf face edge with screws and wood glue. You could use brad nails and wood glue here but then you will have to fill nail holes.

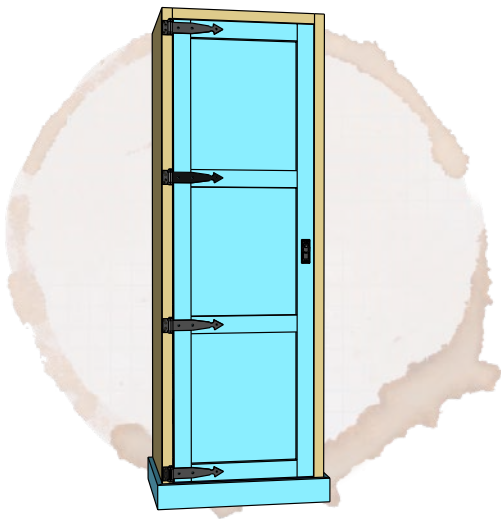

7

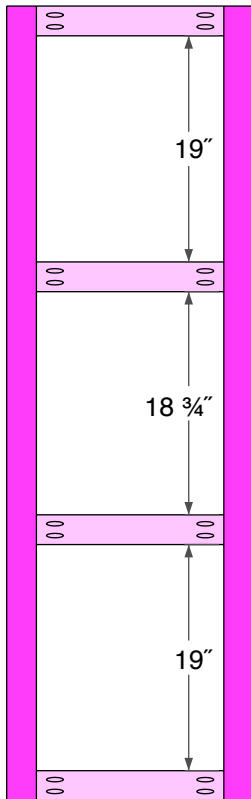

8

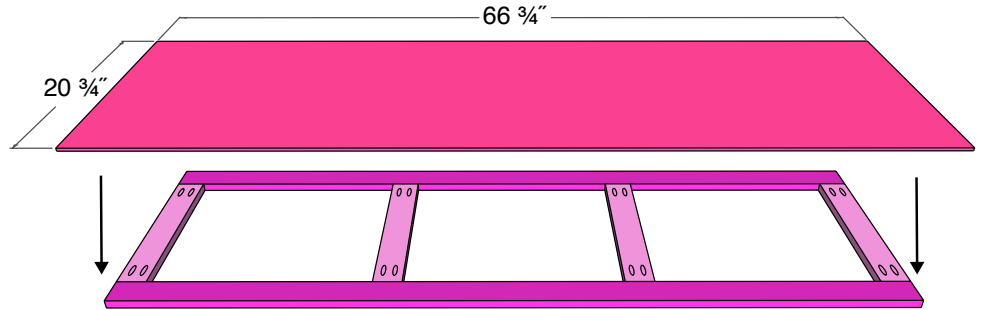

9

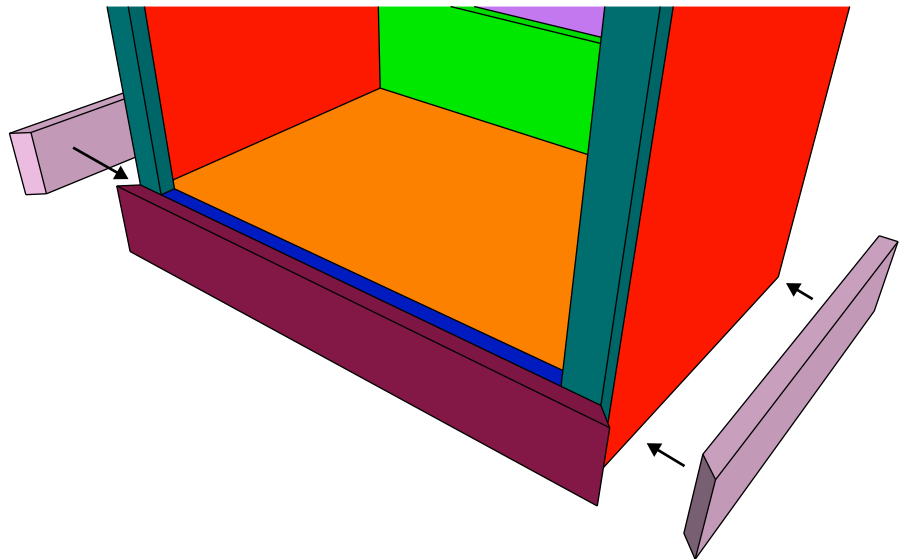

7.

To build your door first you will build the frame. Following the above left illustration, drill for 1-1/4" pocket screws and attach with screws and wood glue.

8.

Now cut the door's back panel to fit flush with the outside edges of the door frame. Attach with 3/4" staples and wood glue.

9.

For the bottom trim first miter one end of the front (dark purple) board. Now hold it in place at the front and mark where the outside edge of the miter on the other end will be. Cut it a little longer than needed and continue to creep up on the proper length. Don't attach yet. Cut a joining miter on a piece of molding to meet up with the right side edge of the front molding and, holding it in place, mark for the length at the back. Now reset your miter saw for a straight cut and cut your right side molding to length. Check for proper fit. Now repeat for the left side. After all the pieces fit snug, attach with 1-1/4" brad nails and wood glue.

NOTE - if you are building multiple lockers you will want to wait to do the trim until you have installed all the lockers onto your wall. Then cut and attach one long trim board across all the front of the lockers for a built-in look.

10

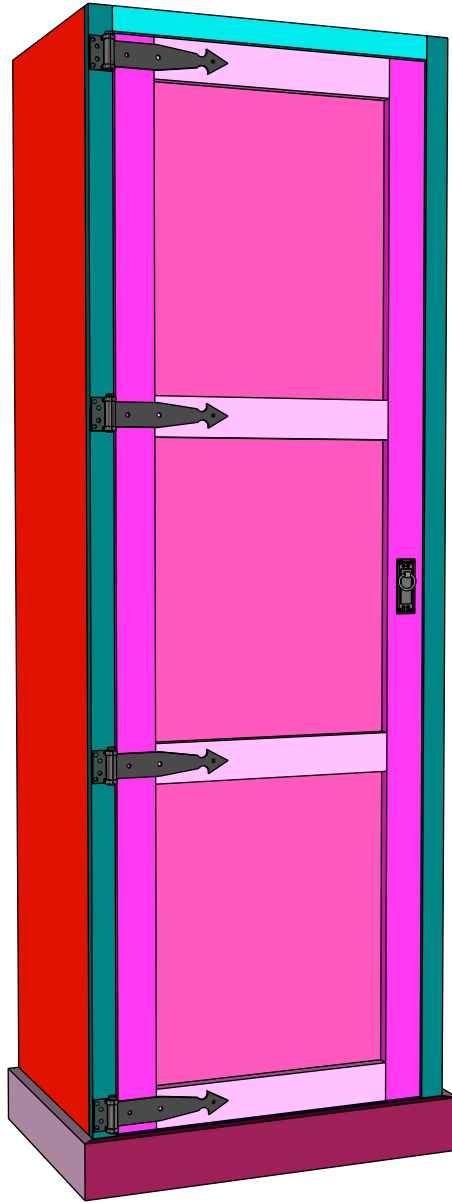

10.

Now lets bring it all together. Using three or four hinges of your choice attach the door so that it has an equal 1/8" gap all around. Shims work great here to get an even gap.

Then attach your door handle hardware.

Once the locker is complete and set it in place you will want to secure it to the wall. Locate two studs and drill pilot holes for two 3" spax screws into the upper horizontal 1x6 bracing. Drive the 3" spax screws.

NOTE - If you are planning on installing multiple lockers you will want to secure the lockers to each other as well. Clamp the face frames of two adjoining lockers so that they are flush with each other. Drill pilot holes for 1-1/4" spax screws through the side panels close to the front inside corner at two or three locations vertically. Make sure you don't drill through the other side. Carefully drive the screws to secure the lockers. Continue this process with each locker.

Then attach your base trim across all the lockers for a great built-in look.