



©2017 WWW.SHANTY-2-CHIC.COM



DIY LOFT BED

SUPPLY LIST

Item	Quantity	Description
2x10x8	4	Pine or Common Board
2x4x8	14	Pine or Common Board
2x2x8	11	Pine or Common Board
1x4x8	12	Pine or Common Board
3/4"x48"x96" Hardwood Plywood	2	Birch
1 1/4" Pocket Hole Screws		
2 1/2" Pocket Hole Screws		
1 1/4" Brad Nails		
3" Wood Screws		
1 1/4" Wood Screws		
Wood Glue		

Remember!

Many of these cuts are best made as you go. If you have questions, check out the tutorial on our site!

CUT LIST (page 1)

This is a cut list for the entire bed. This set of plans is for part one of the bed build.



Remember!

Many of these cuts are best made as you go. If you have questions, check out the tutorial on our site!

CUT LIST (page 2)

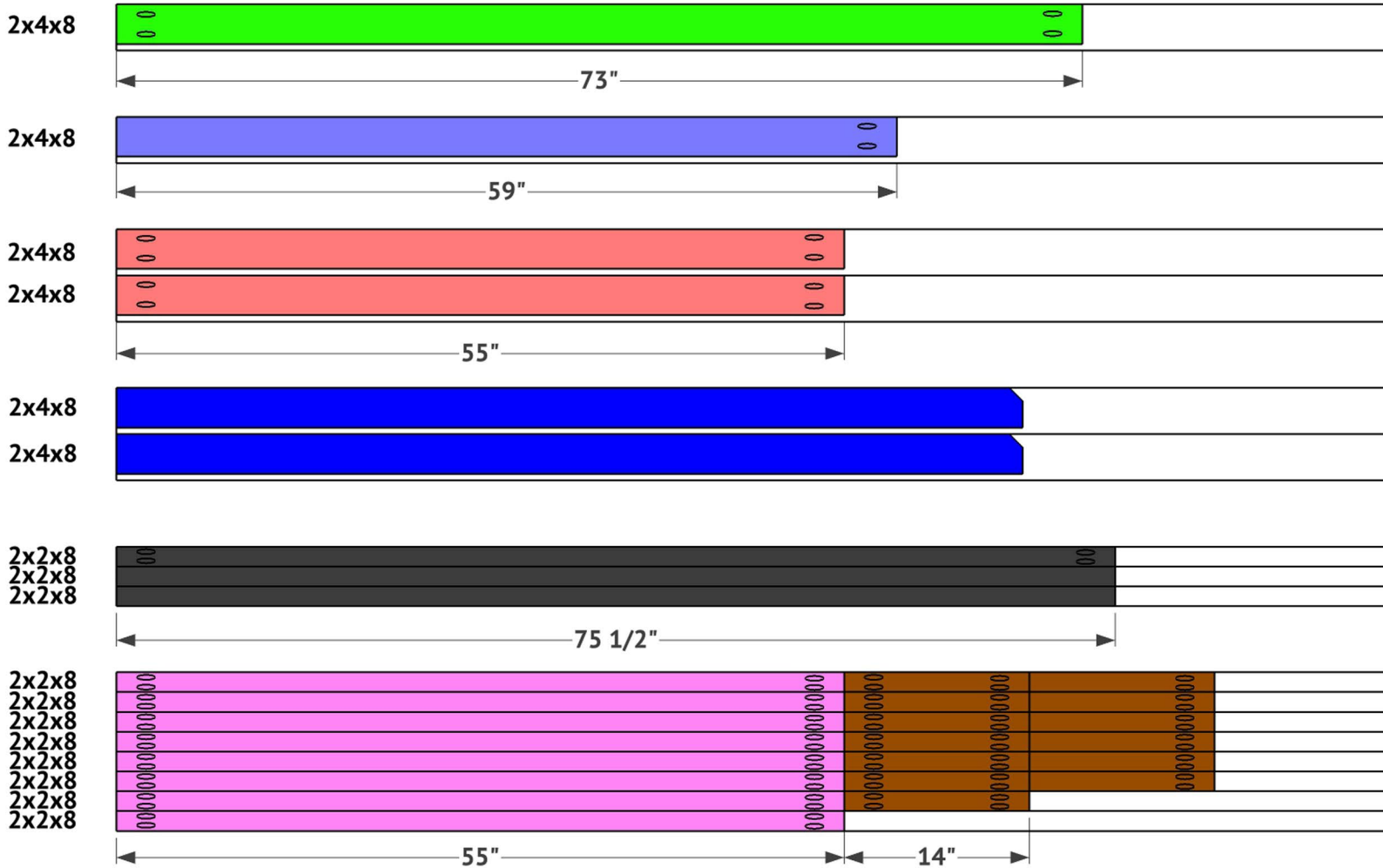

Miter Detail:



Remember!

Many of these cuts are best made as you go. If you have questions, check out the tutorial on our site!

CUT LIST (page 3)

1x4x8	
1x4x8	
1x4x8	
1x4x8	
1x4x8	
1x4x8	
1x4x8	
1x4x8	
1x4x8	
1x4x8	
1x4x8	
1x4x8	
1x4x8	
1x4x8	
1x4x8	

55"

Remember!

Many of these cuts are best made as you go. If you have questions, check out the tutorial on our site!

CUT LIST (page 4)

**3/4"x48"x96"
Hardwood Plywood**

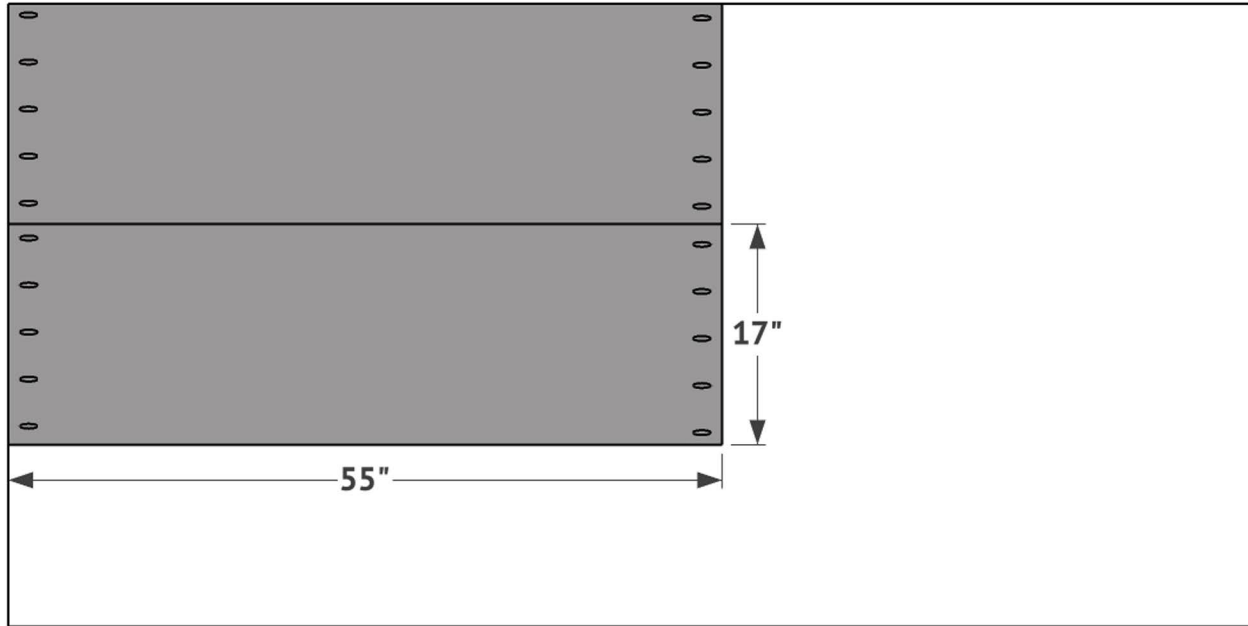

**3/4"x48"x96"
Hardwood Plywood**

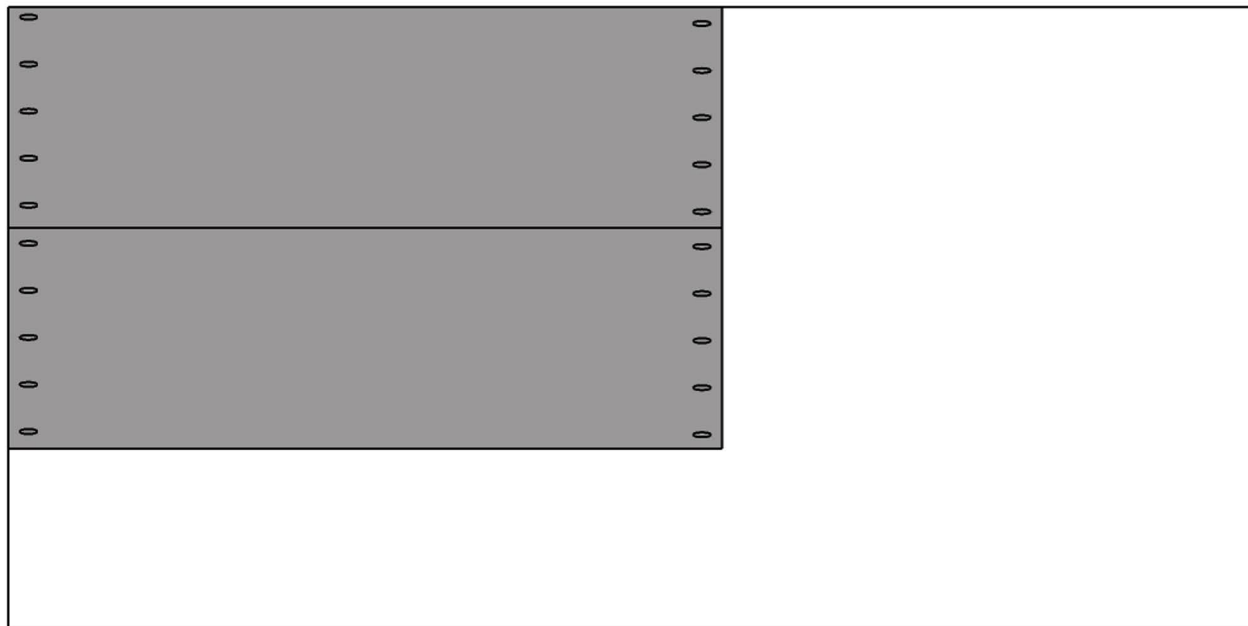

Loft Bed Plans Part 2

1

Cut the front shelf trim pieces to size and drill 1 1/2" pocket holes on each end. Attach them to the leg supports with 2 1/2" pocket hole screws and wood glue.

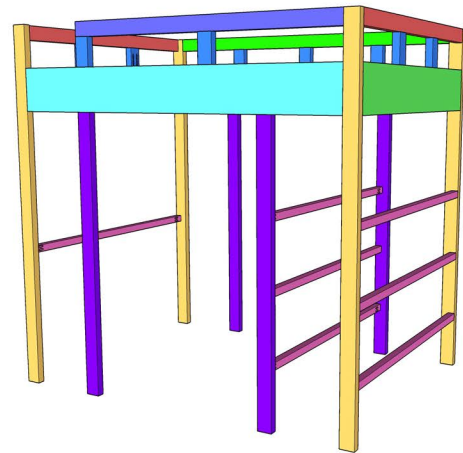
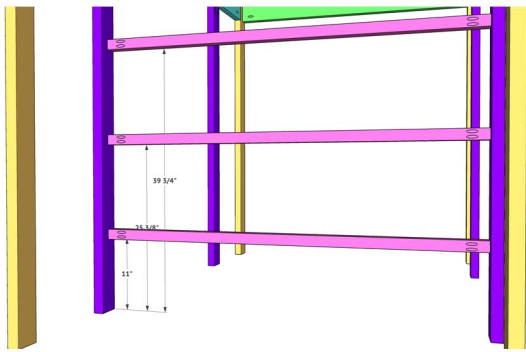

2

Cut the front desk trim piece to size and drill 1 1/2" pocket holes in each end. Attach it to the leg supports with 2 1/2" pocket hole screws and wood glue.

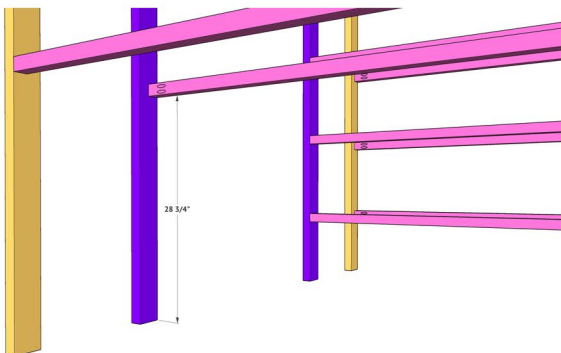

3

Cut the short shelf pieces to size and drill 1 1/2" pocket holes in both ends. Attach them to the leg supports with 2 1/2" pocket hole screws and wood glue. The pocket holes on the bottom pieces will face in and the rest will face down.

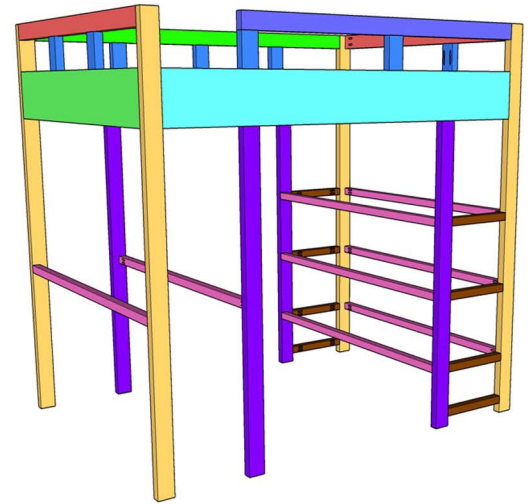
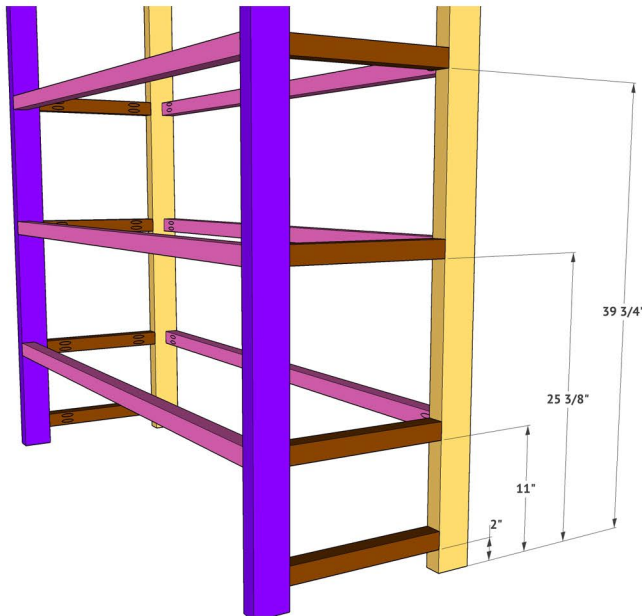

4

Cut the short desk pieces to size and drill 1 1/2" pocket holes in both ends. Attach them to the leg supports with 2 1/2" pocket hole screws and wood glue. The pocket holes on the bottom pieces will face in and the rest will face down.

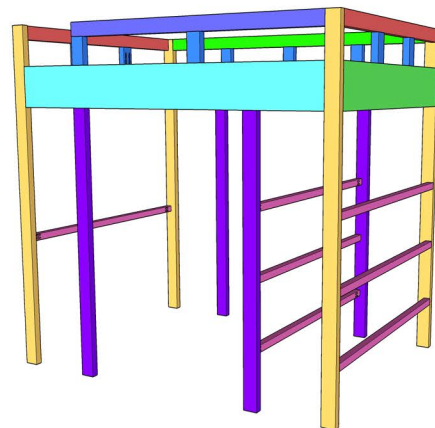
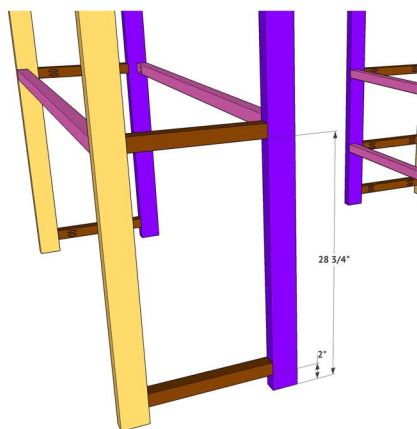

5

Measure and cut the plywood for the shelves. Drill 3/4" pocket holes around all edges and attach it to the shelf trim with 1 1/4" pocket hole screws. The plywood should be flush with the top of the trim.

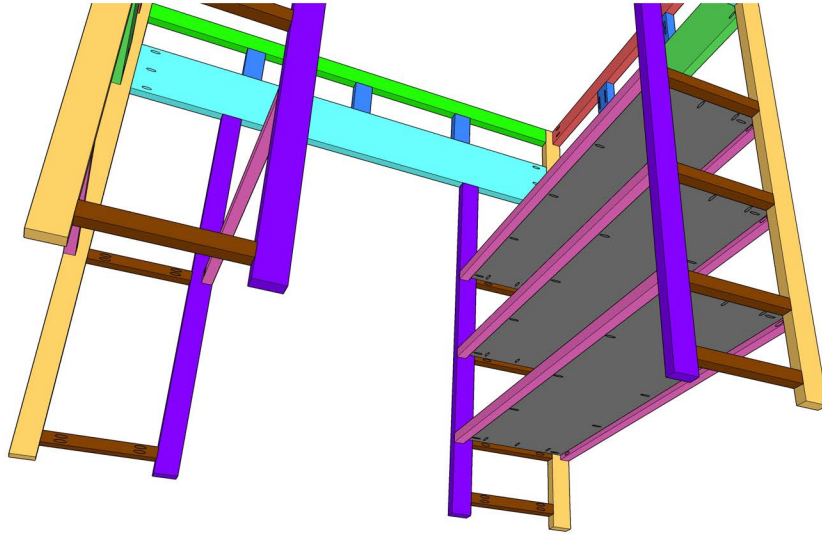

6

Measure and cut the plywood for the desk. Drill 3/4" pocket holes around all edges and attach it to the shelf trim with 1 1/4" pocket hole screws. The plywood should be flush with the top of the trim.

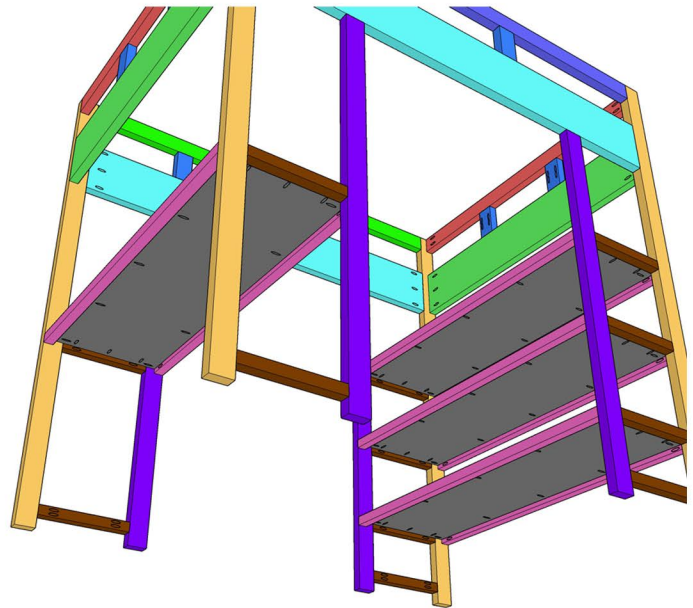



Cut the ladder pieces to size. Drill 1 1/2" pocket holes on both ends of each rung.

Attach the rungs to the ladder legs with 2 1/2" pocket hole screws and wood glue. Attach the ladder to the loft bed with 3" wood screws, from the back of the leg supports and into the ladder.

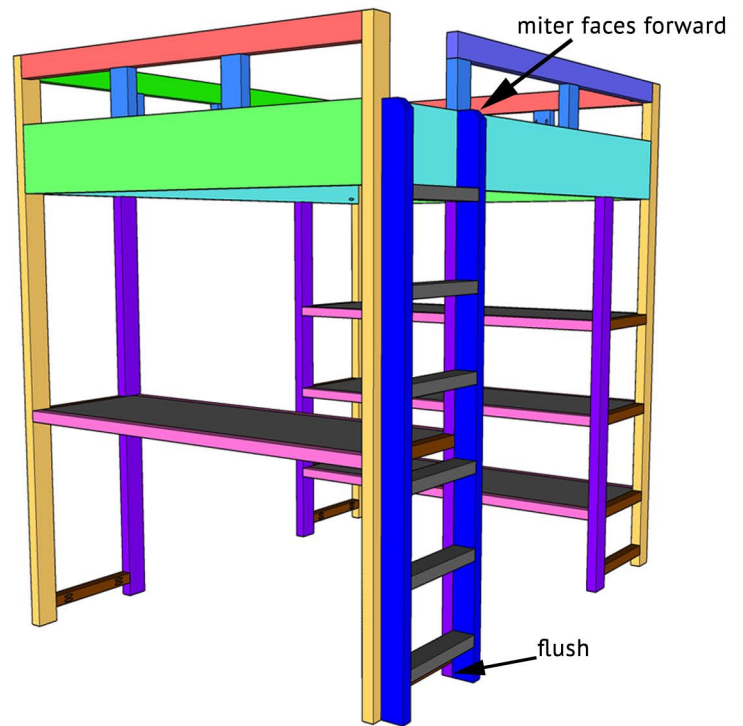
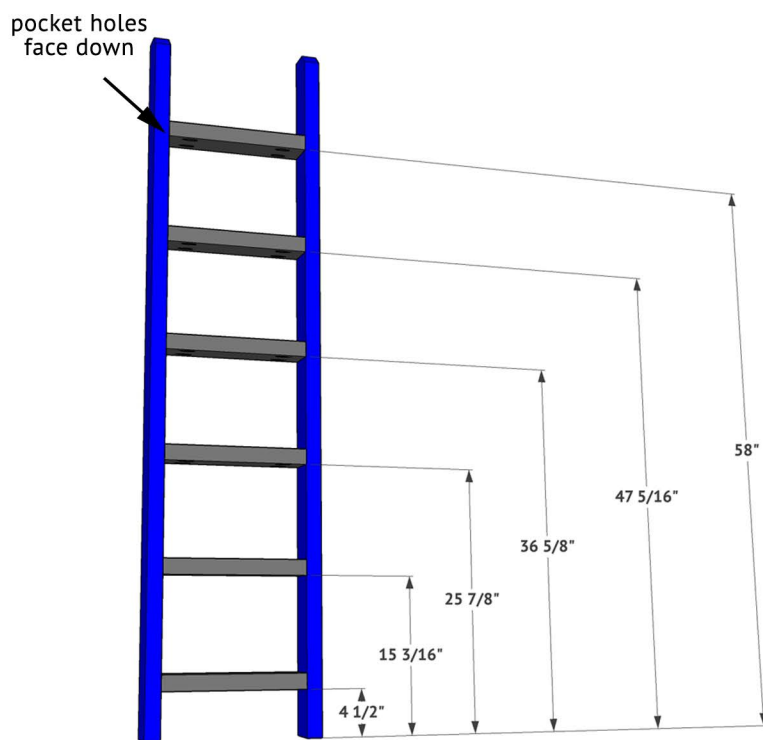

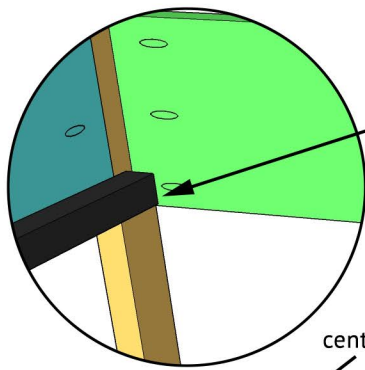

bottom of cleats
flush with bottom
of mattress frame



Cut the cleats to size and drill 1 1/2" pocket holes at both ends. Attach one to each side of the bed with 2 1/2" wood screws and 2 1/2" pocket hole screws and wood glue. Attach the center cleat with 2 1/2" pocket hole screws and wood glue.

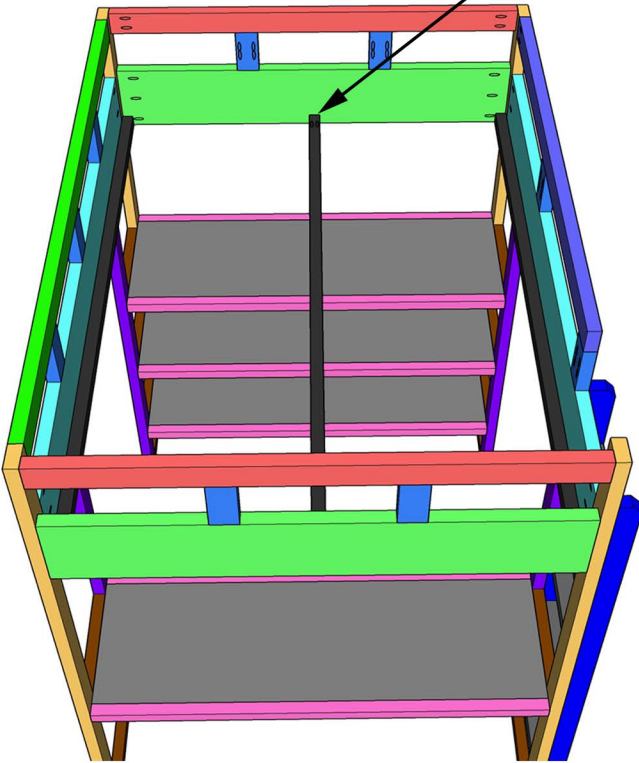

Cut the slat pieces to size. Even space them out across the cleats and attach them to the cleats with 1 1/4" wood screws.

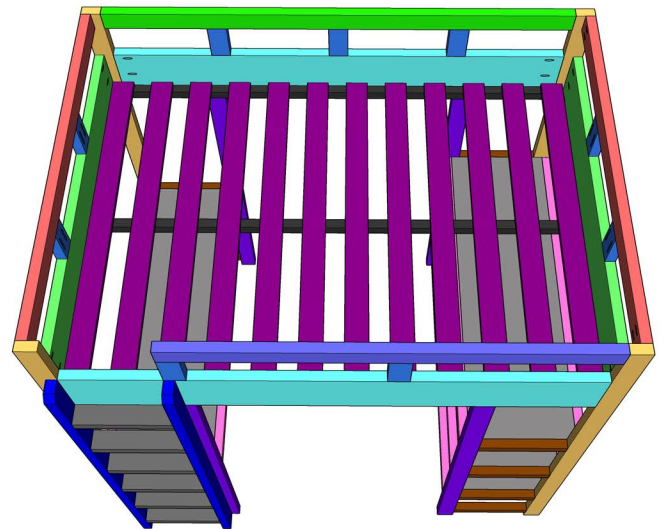

Now just fill your exposed pocket holes,
sand it down and add a finish!

Make sure to share your builds with us on
social media and use #shanty2chic so
we can share them too!

Happy Building!

