



©2022 WWW.SHANTY-2-CHIC.COM



Modern Farmhouse Turned Leg Dining Table

Supply List

Item	Quantity	Description
2 x 6 x 8 boards	11	framing lumber
2.5" pocket hole screws	several	
Turned Wood Legs	4	Carolina Leg Co - Check post for link!

Remember!

Many of these cuts are best made as you go. If you have questions, check out the tutorial on our site!

CUT LIST

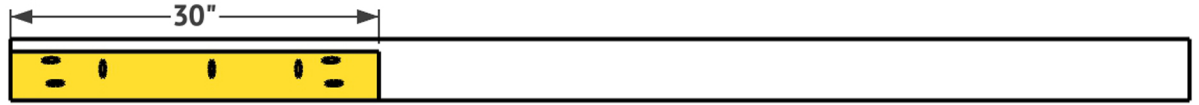

3 - 2x6x8
ripped to 4"

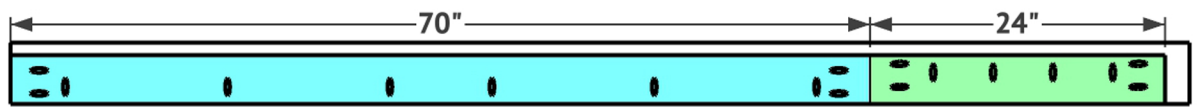
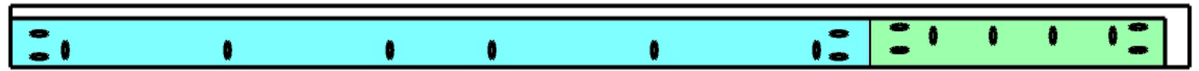

8 - 2x6x8
ripped to 5"

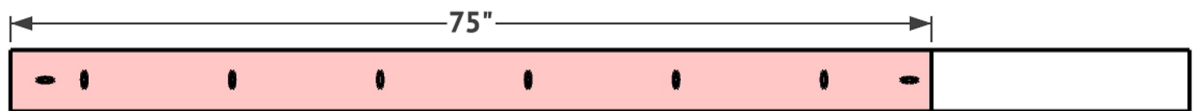

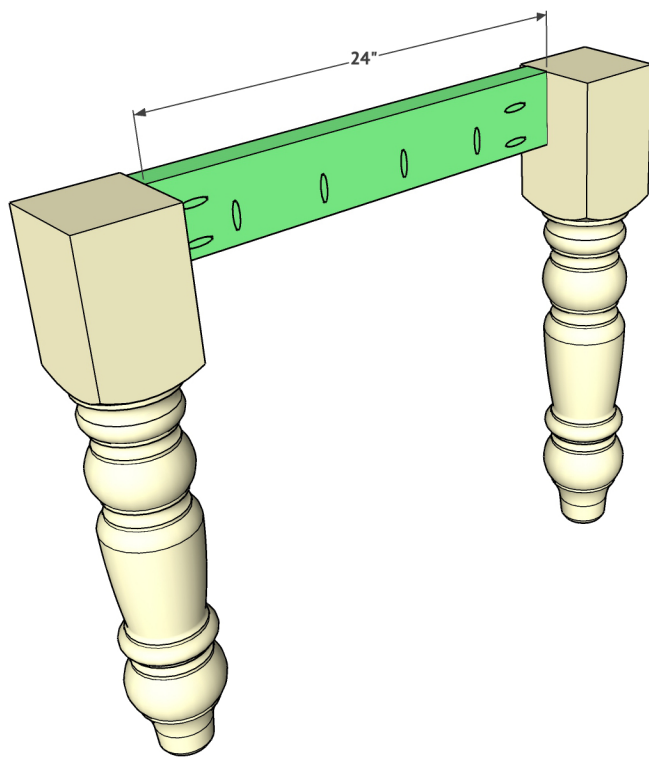

1

Before assembly, I ripped all of my 2 x 6 boards to size. All of the boards used to construct the apron are ripped to 4" each, and all of the boards used to plank the top of the table are ripped to 5" each. I find it easiest to make my short cross cuts first and then rip each board down. To me, it makes it easier to push them through the table saw when they are shorter lengths.

Add 1.5" pocket holes down the long sides of each apron board and also add two 1.5" pocket holes on each short end. Attach the shorter apron boards to the legs using 2.5" pocket hole screws and wood glue. The top of the apron will be flush with the top of each leg and you want a 1/2" inset from the top sides of the legs.

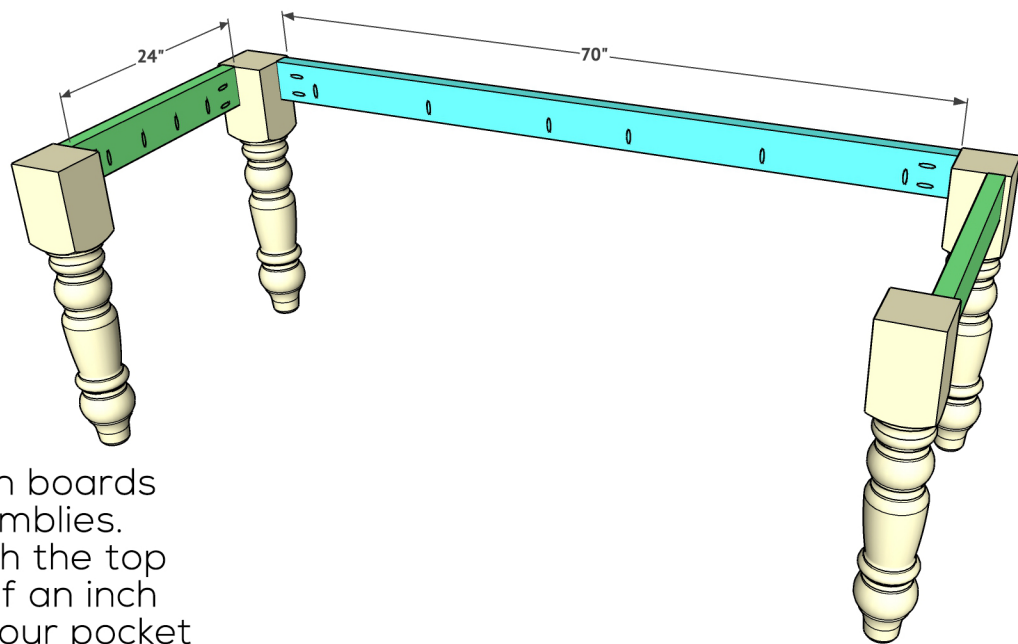

2

Now attach the long apron boards to both of your leg assemblies. These will also be flush with the top of the legs and inset 1/2 of an inch from the sides. Make sure your pocket holes that run the length of the apron face up to attach the table top and a later step.

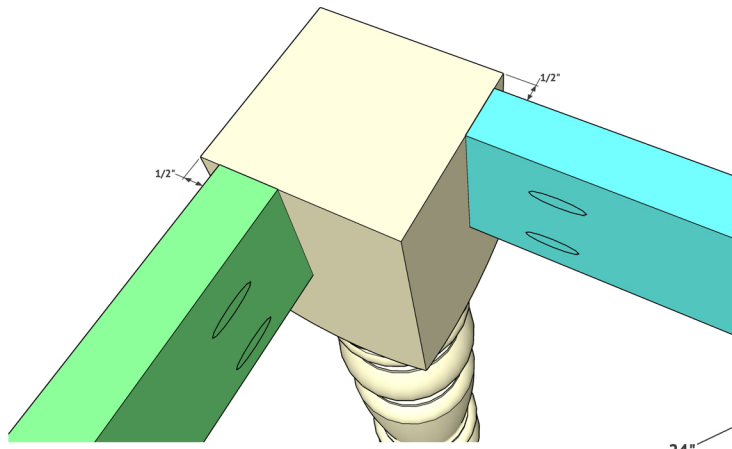

Note the placement of the apron boards on each leg. The top of the aprons are flush with the top of the legs. The apron boards are each set in by 1/2".

The final step of assembling the base is adding the 2 x 4 in the center of the table. This will run parallel with your short aprons and centered on the long aprons. Attach this board using wood glue in 2 1/2" pocket hole screws. Make sure the pocket holes running the length of this board face up to attach the table

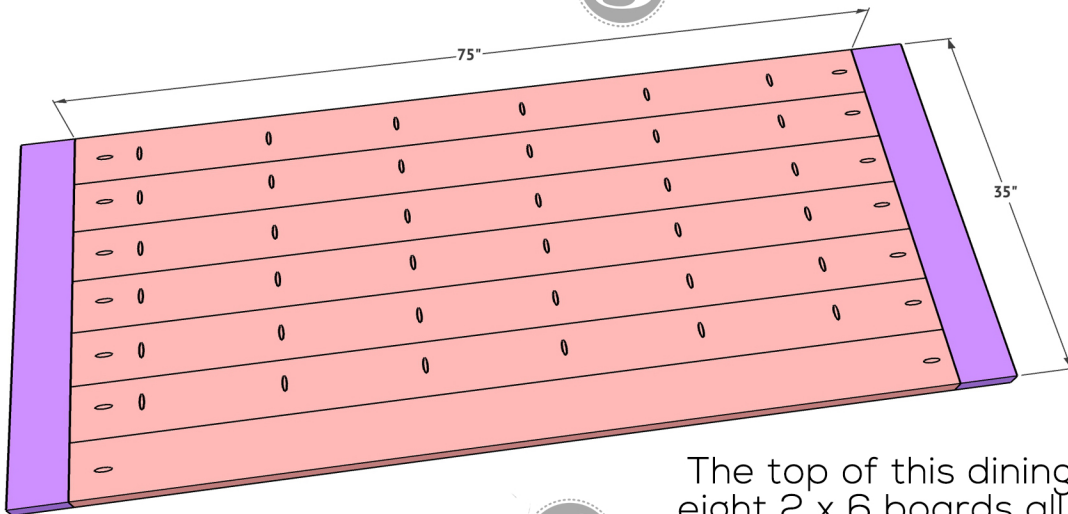
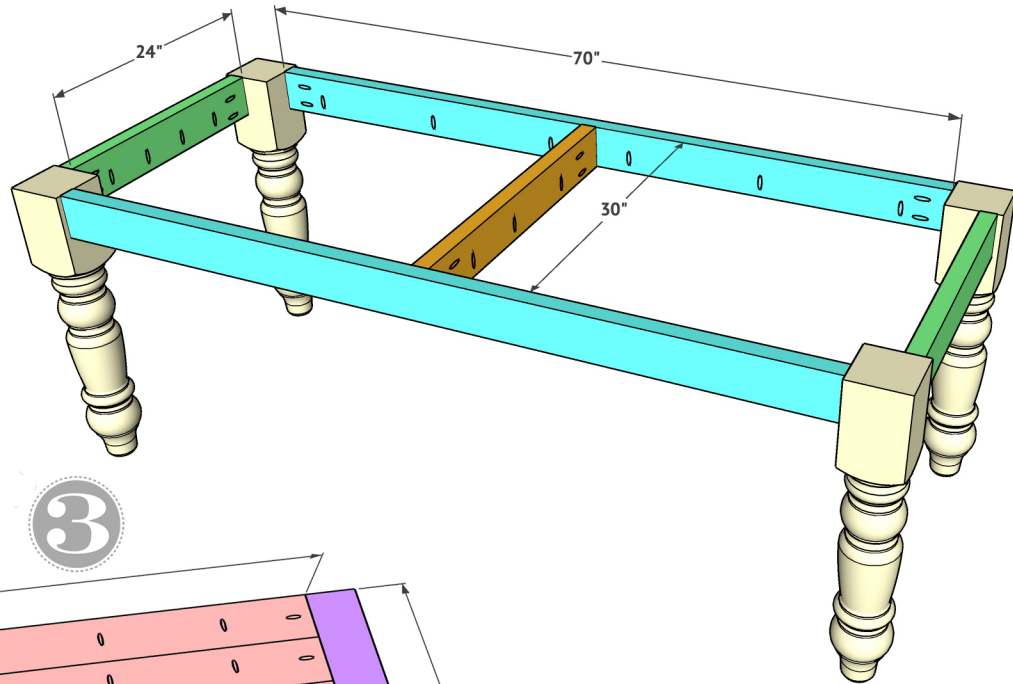

The top of this dining table is built with eight 2 x 6 boards all ripped to 5" each. I decided to make this table more narrow after I got it built because I liked the way that it looked and fit in my dining room. You can definitely add the eighth board for a more traditional width. Add 2 1/2" pocket holes down six of the seven longer boards and also add two pocket holes on each short end of all seven long boards to attach your breadboards. Plank all seven long boards together with 2 1/2" pocket hole screws. Measure and cut your bread boards and attach them through the pocket holes at the end of the longer boards with 2 1/2" pocket hole screws.

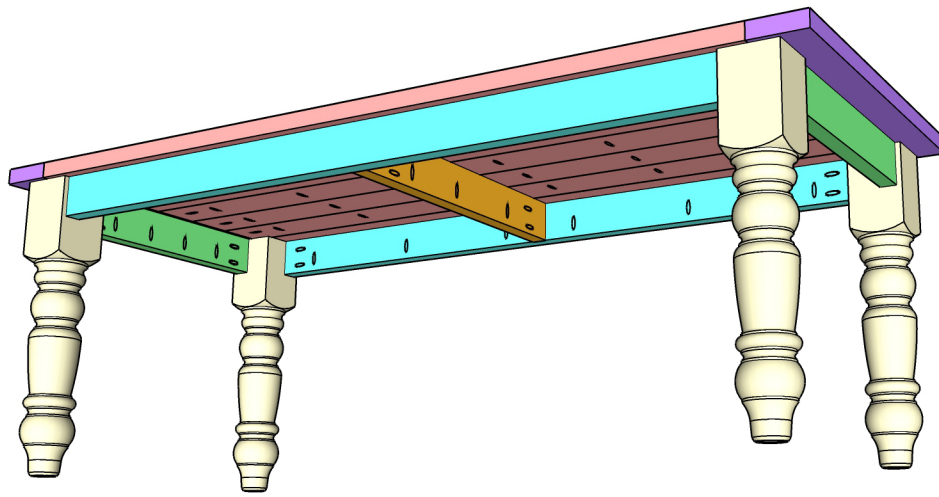

5

The final step of building the dining table is attaching the table top to the table base. We always wait for this step until after we get it placed in the room where it will stay. We like to stain or finish at this point, and then move the table into the room in two separate pieces. To attach the table top use 2 1/2" pocket hole screws through all of the pocket holes you added on the apron boards and up into the table top. There will be a 2 1/2" overhang on each short end and a 1/2" overhang on the longer sides.

Make sure to share all of your builds with us on social media using #shanty2chic so we can see and share them!

Happy building!