



©2017 WWW.SHANTY-2-CHIC.COM



# MODERN COFFEE TABLE

## SUPPLY LIST

Item	Quantity	Description
2x4x8	4	Framing Lumber
2x6x8	12	Framing Lumber
2 1/2" Pocket Hole Screws		
Wood Glue		

*Remember!*

Many of these cuts are best made as you go. If you have questions, check out the tutorial on our site!

# CUT LIST

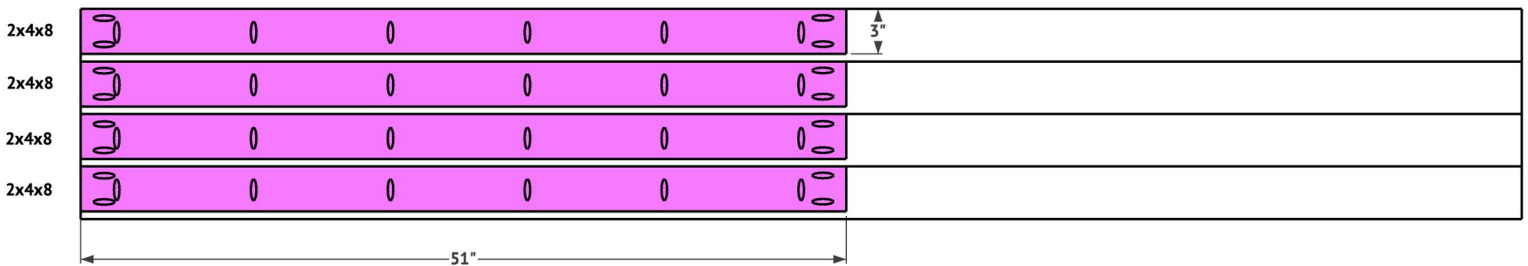
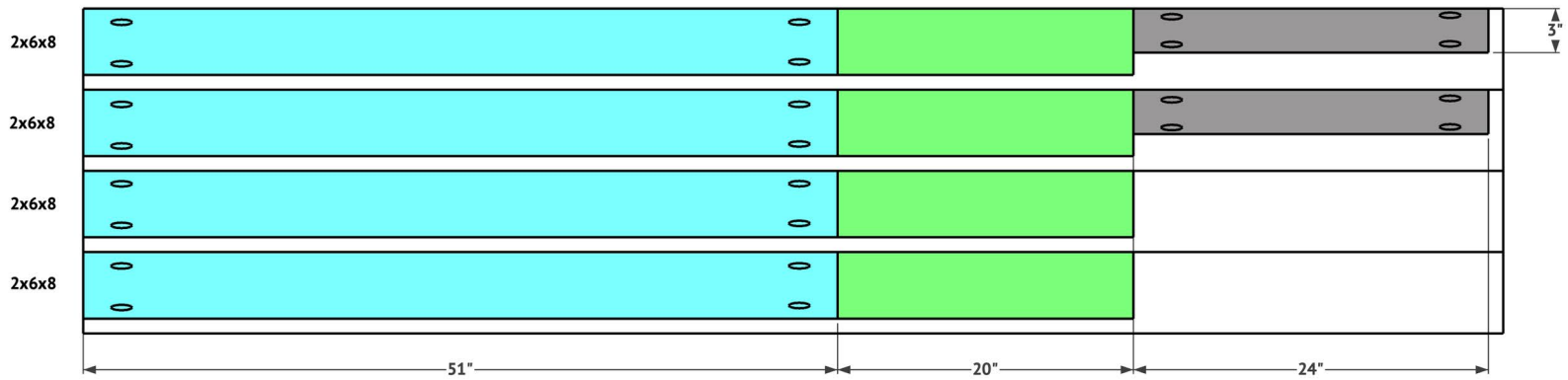
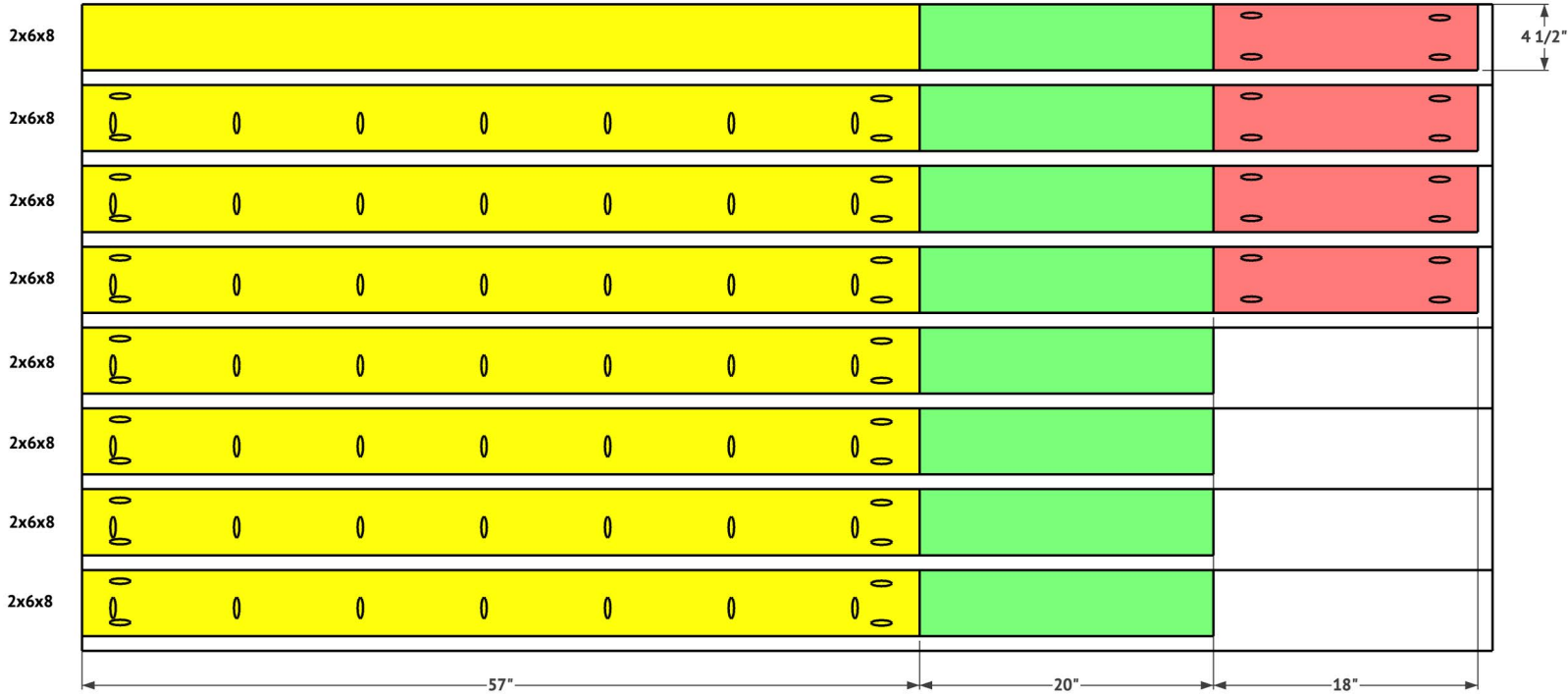

1

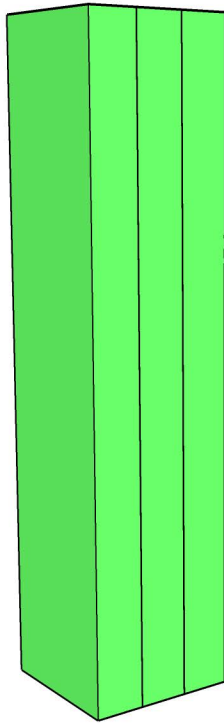

x4

Cut the leg pieces to size. Stack 3 pieces together, with wood glue, and clamp for 24 hours. Build 4 leg assemblies.

2

Cut the planks to size and drill 1 1/2" pocket holes on one edge and both ends of each plank. Attach them together with 2 1/2" pocket hole screws.

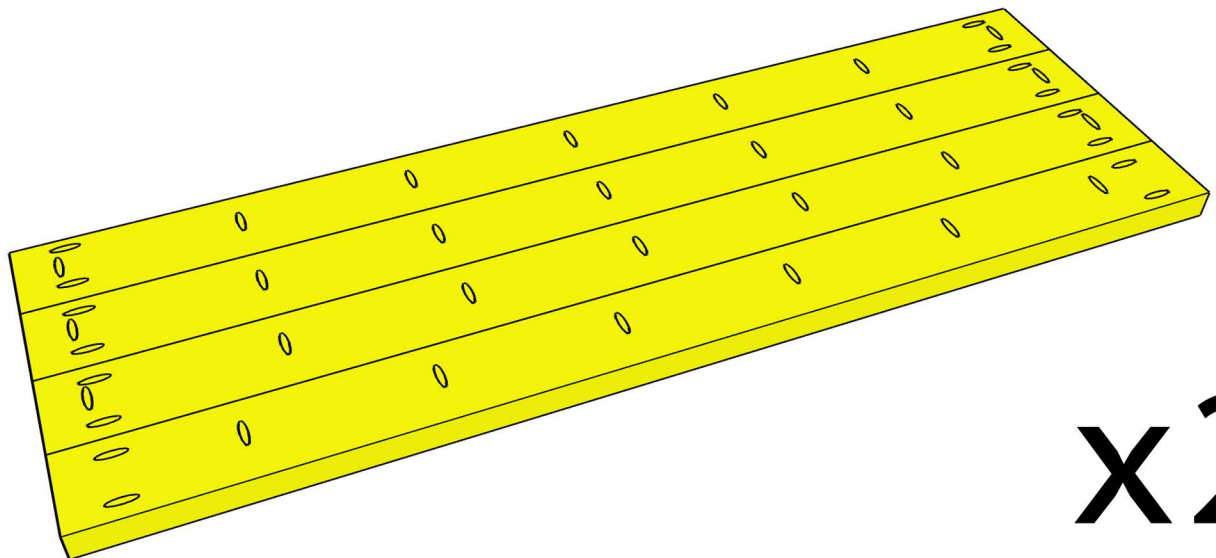

x2

3

Cut the outside planks to size and drill 1 1/2" pocket holes on one edge and both ends. Attach 2 of the planks to 2 legs with 2 1/2" pocket hole screws and wood glue. Do this for both sides.

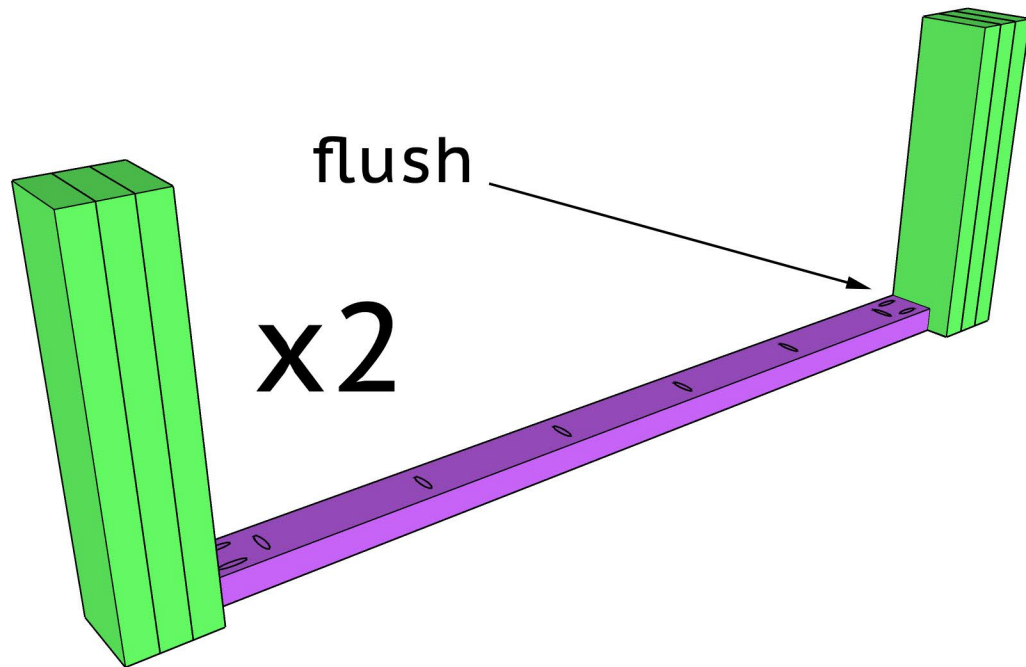

4

Cut the short apron pieces to size and drill 1 1/2" pocket holes on both ends. Attach them to the ends of both plank assemblies with 2 1/2" pocket hole screws and wood glue.

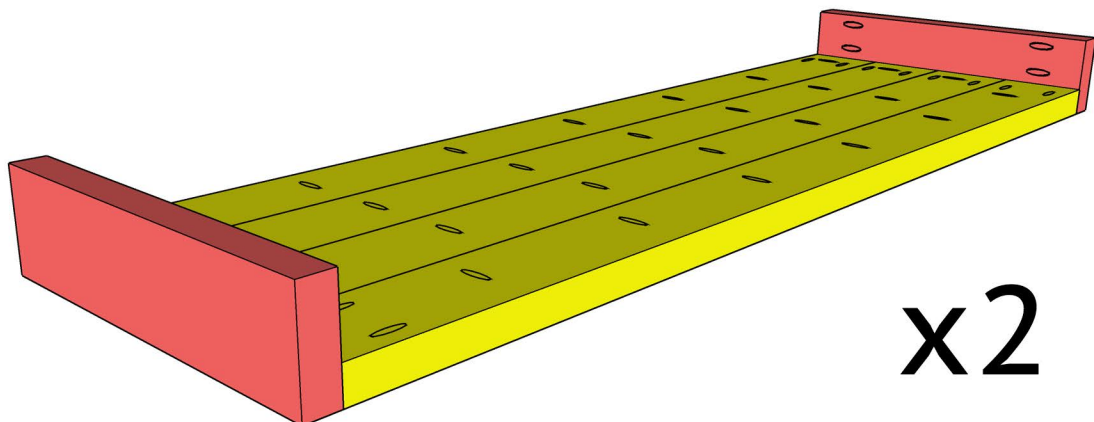

5

Attach both leg assemblies to the top plank assembly with 2 1/2" pocket holes and wood glue, through the side aprons and into the legs.

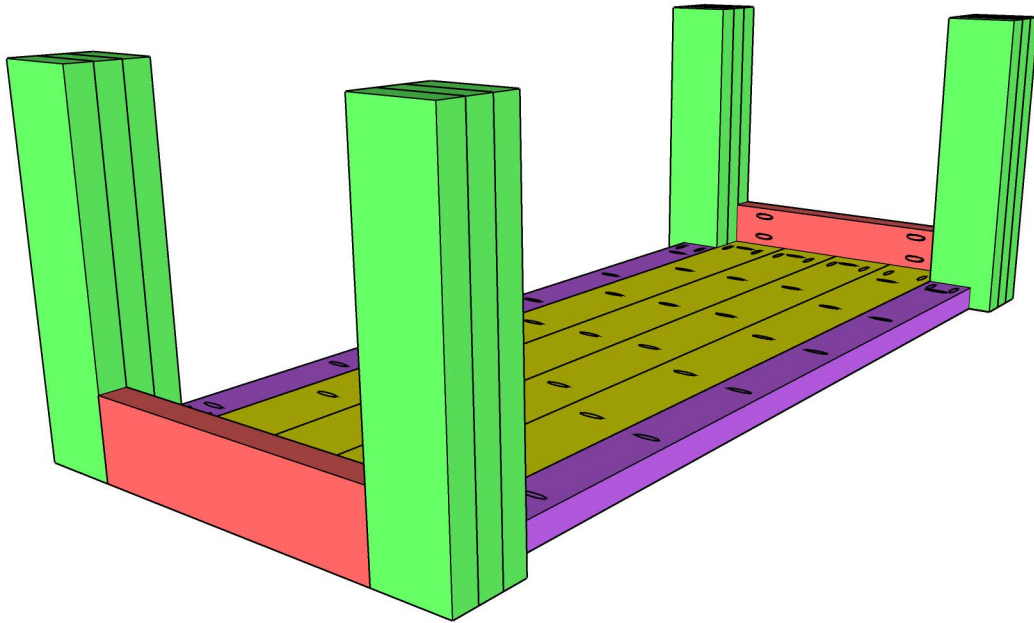

flush with  
bottom of legs

6

Attach the bottom plank assembly to the bottom of the legs with 2 1/2" pocket hole screws and wood glue.

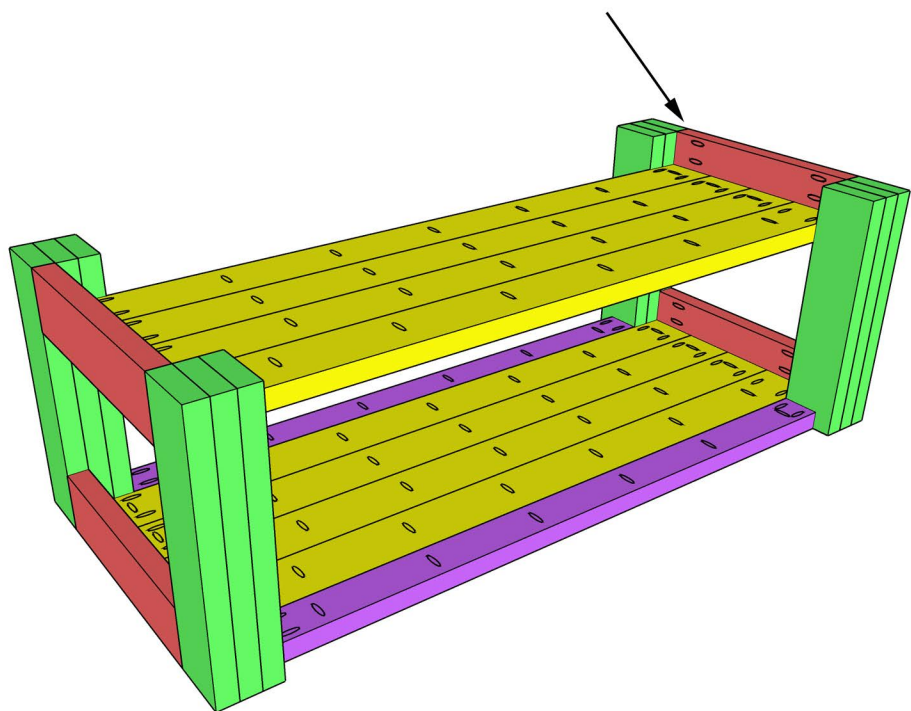



Attach the 2 remaining side planks to the bottom plank assembly with 2 1/2" pocket hole screws and wood glue on the ends (where they attach to the legs).

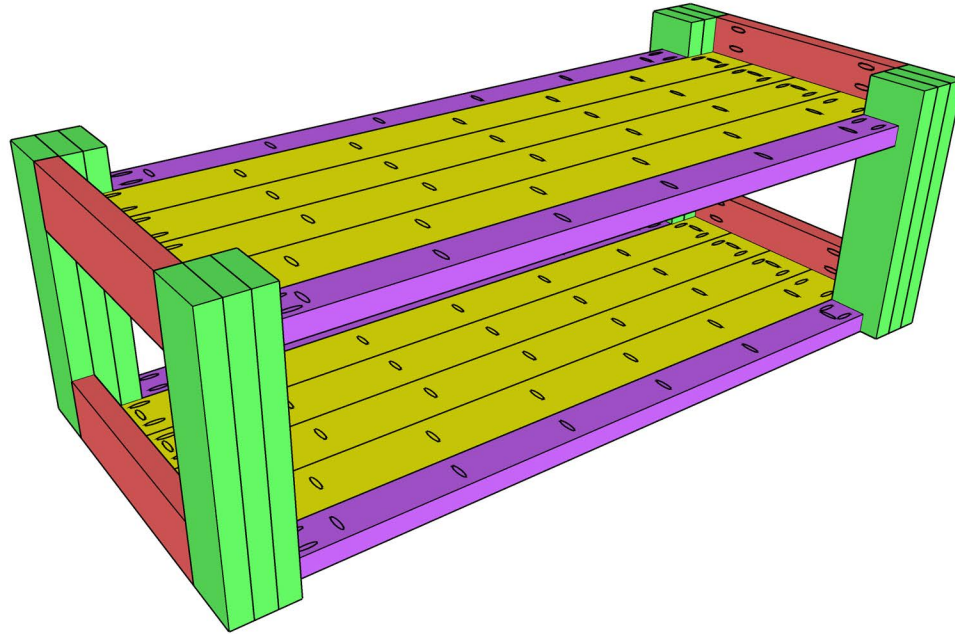

Cut the long apron pieces to size and drill 1 1/2" pocket hole screws at both ends. Attach them to the plank assemblies and legs with 2 1/2" pocket hole screws and wood glue.

flush with  
bottom of legs

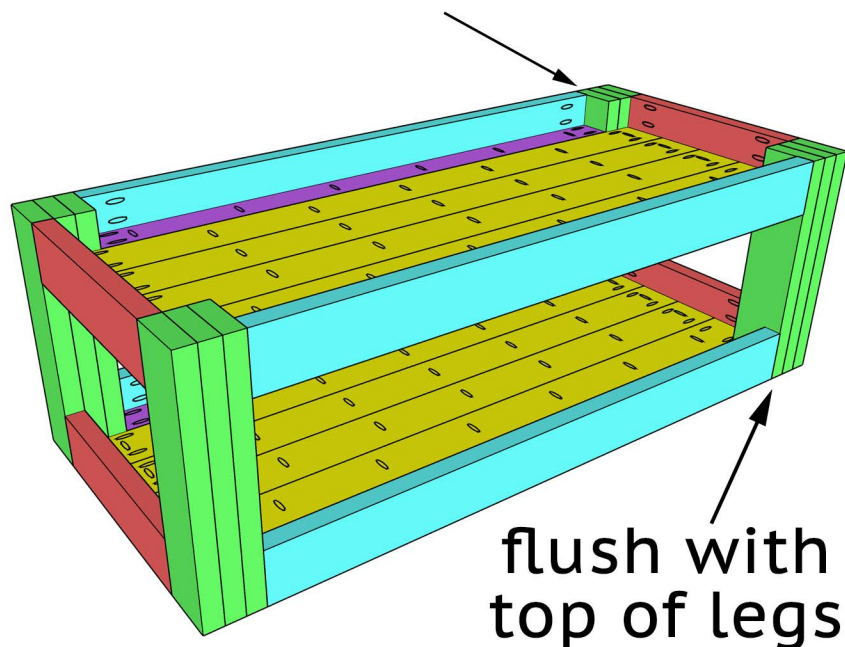

flush with  
top of legs



Cut the support pieces to size and drill 1 1/2" pocket holes at both ends. Center them under both plank assemblies and attach them to the long aprons with 2 1/2" pocket hole screws and wood glue.

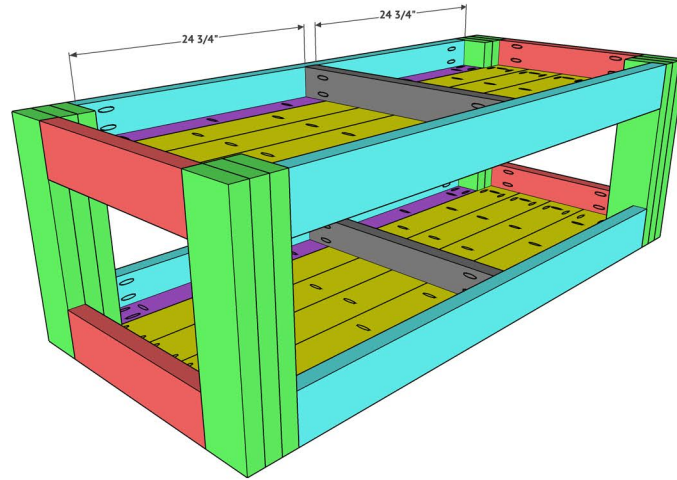

Sand down the entire table and add a finish! Make sure to share your builds with us on social media and use #shanty2chic so we can share them too!  
Happy Building!

