



©2017 WWW.SHANTY-2-CHIC.COM



DIY Dining Table

SUPPLY LIST

Item	Quantity	Description
2x6x8	11	Framing Lumber
Turned Legs	4	Link in the Post on our Site
1 1/4" Pocket Hole Screws		
2 1/2" Pocket Hole Screws		
2 1/2" Wood Screws		
Wood Glue		

Remember!

Many of these cuts are best made as you go. If you have questions, check out the tutorial on our site!

CUT LIST

Note: I ripped the 2x6x8 boards to 5". This is not a necessary step but if you choose not to rip your boards, adjust the plans accordingly.

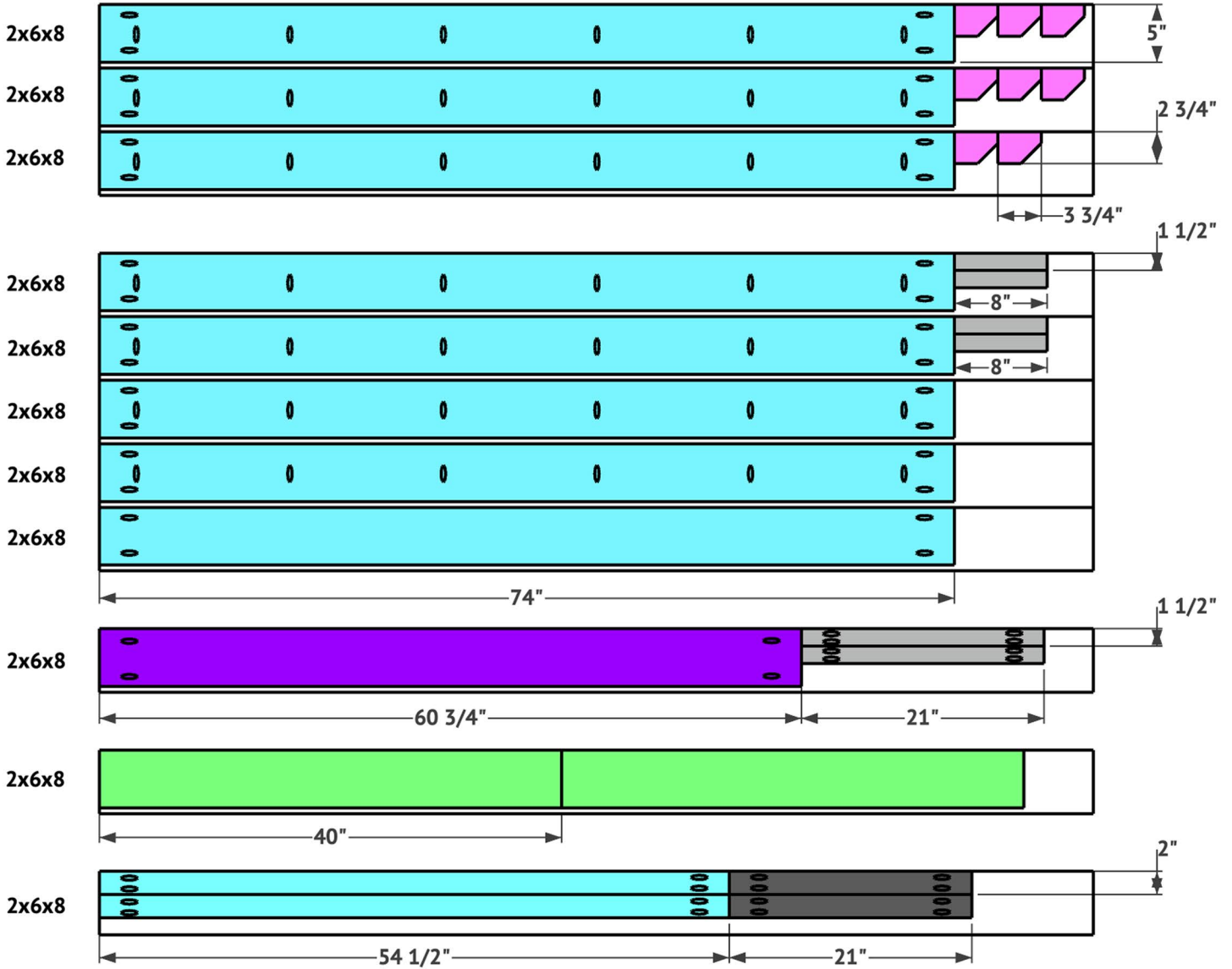

Corner Piece Detail:

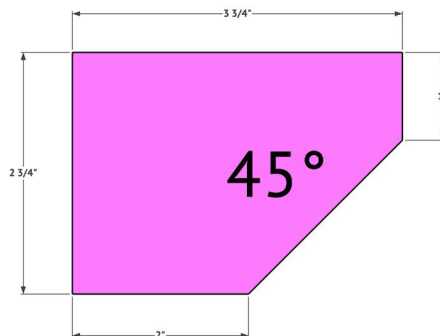

1

Cut the table top planks to size and drill 1 1/2" pocket holes at both ends of each board and one edge of all except one. Attach them together with 2 1/2" pocket hole screws.

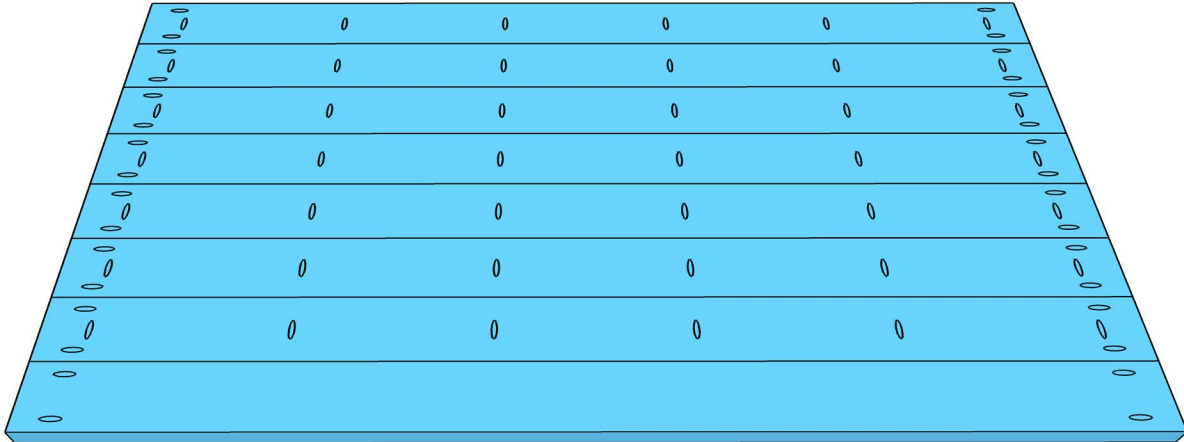

2

Measure and cut the breadboard pieces to size and attach them to the ends of the table top planks with 2 1/2" pocket hole screws, through the pocket holes at the ends of the table top planks.

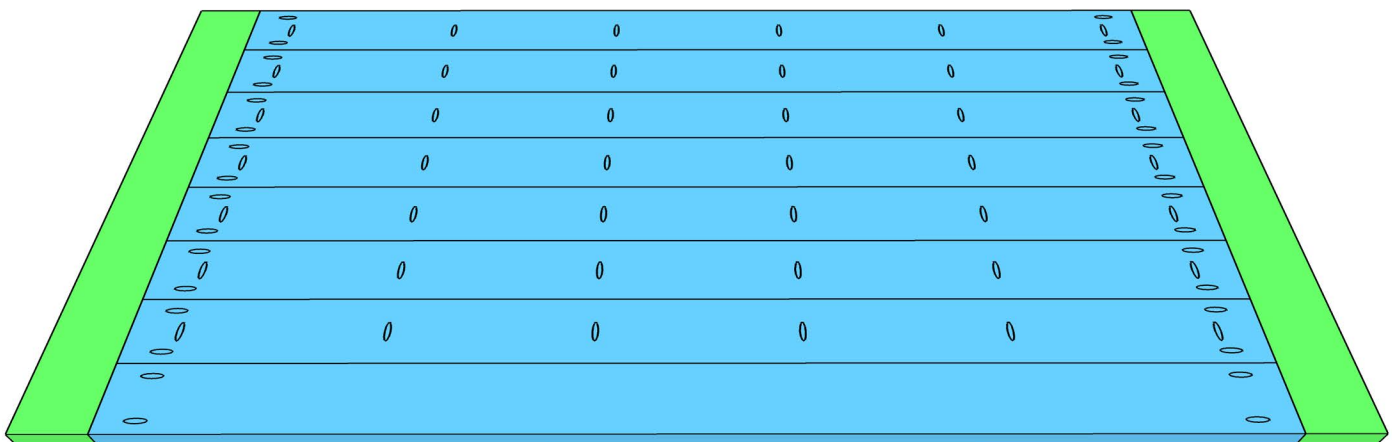

3

Cut the long apron pieces to size and drill 1 1/2" pocket holes at both ends. Center the aprons on two legs and attach them to the legs with 2 1/2" pocket hole screws and wood glue.

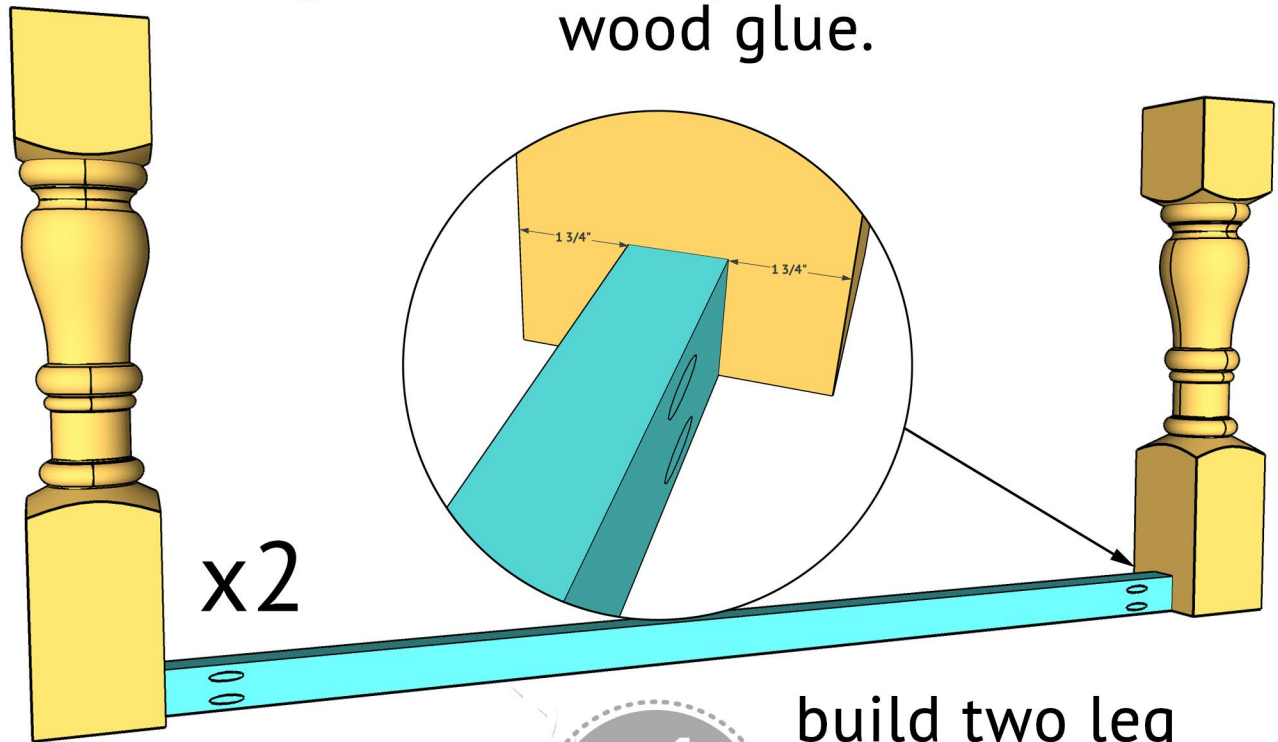

4

build two leg assemblies

Cut the short apron pieces to size and drill 1 1/2" pocket holes at both ends. Center them on the leg assemblies and attach them to the legs with 2 1/2" pocket hole screws and wood glue.

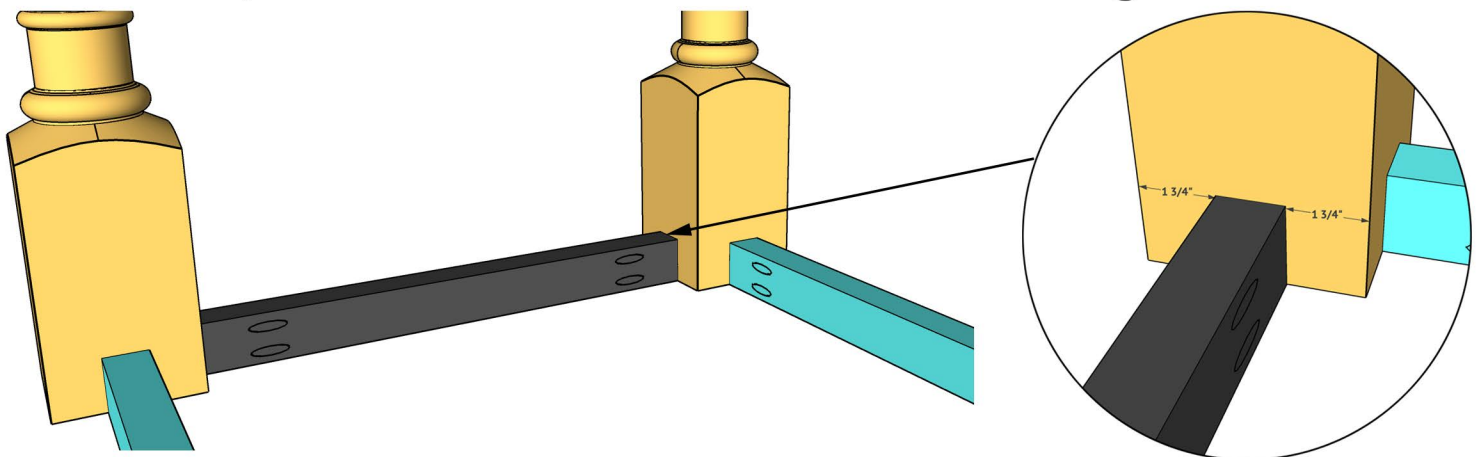

5

Cut the runner support pieces to size and drill 1 1/2" pocket holes at both ends. Attach them to the bottom of the legs with 2 1/2" pocket hole screws and wood glue. The pocket holes should face down, away from the table top.

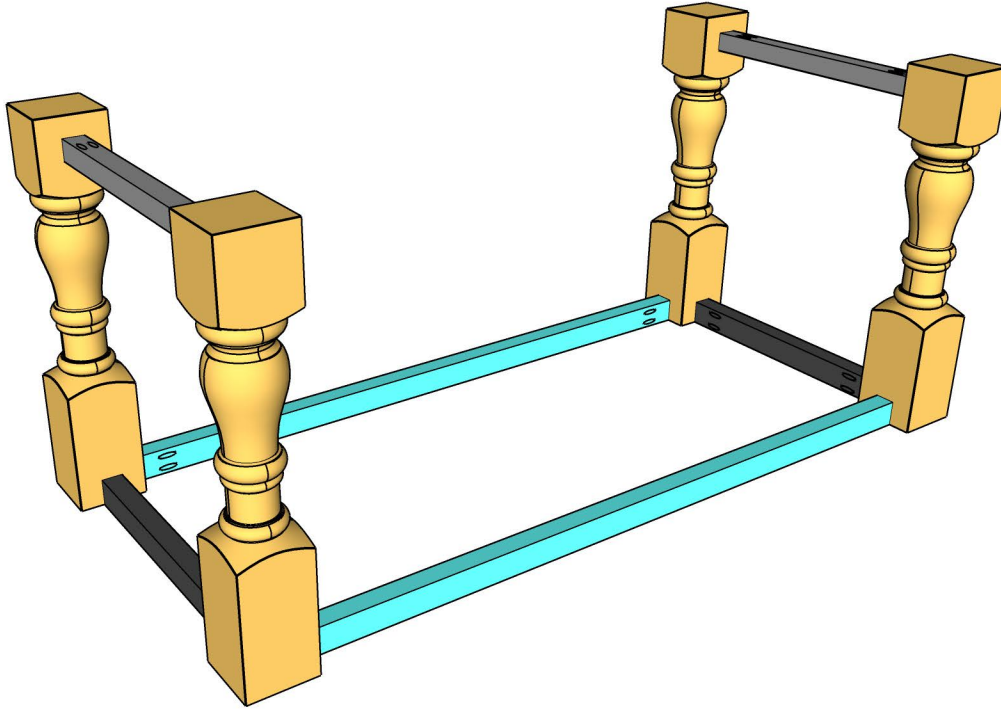

6

Cut the runner to size and attach it to the center of the runner supports with 2 1/2" wood screws and wood glue, from the bottom of the runner support, into the runner.

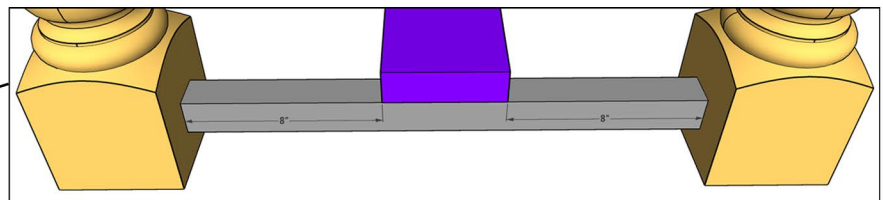
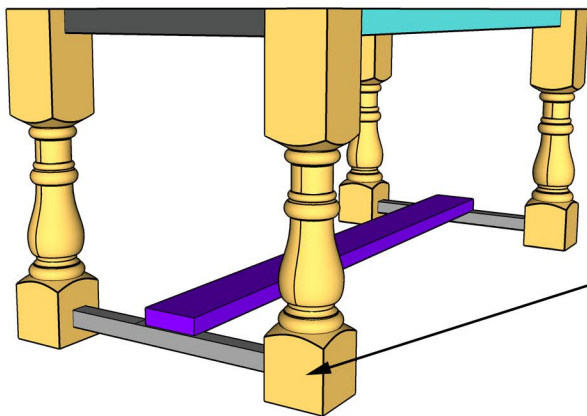



Measure and cut the short trim pieces to size. Attach them to the top of the runner support with 2 1/2" wood screws, from the bottom of the runner support, into the short trim pieces.

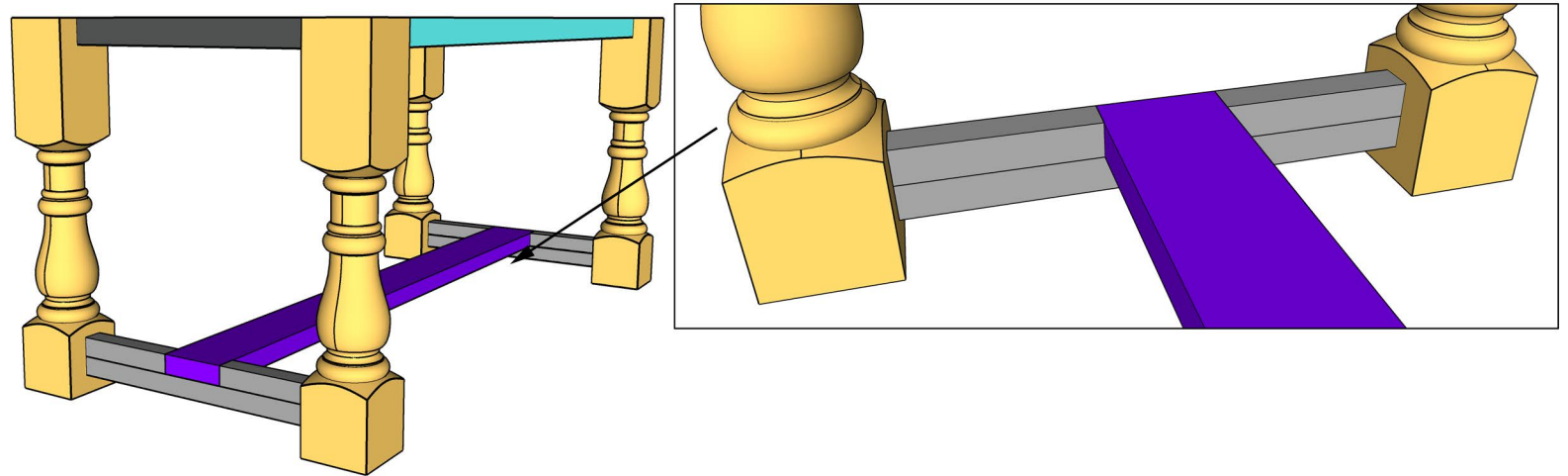

Cut the corner pieces to size and drill a 3/4" pocket hole on the short side and a 1 1/2" pocket hole on the long side. Attach a corner piece to each top corner of the dining table frame with pocket hole screws and wood glue.

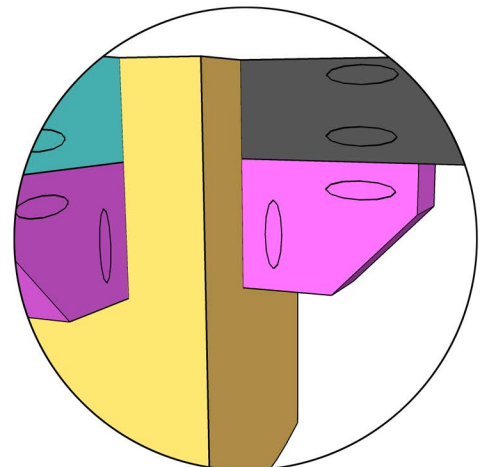
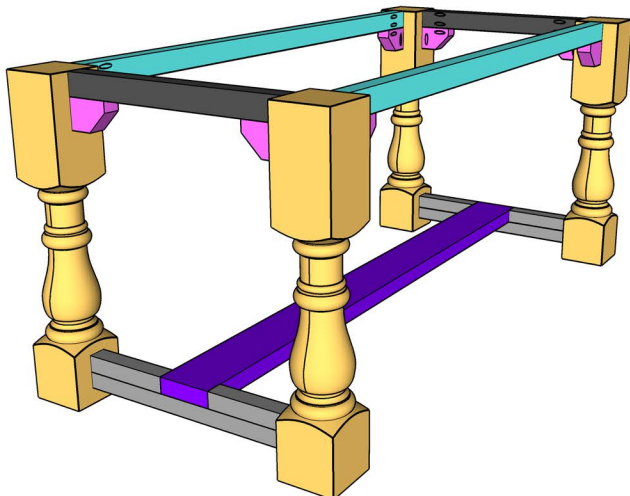

9

Lay the table top upside down and center the base on top. Attach the base to the table top with 2 1/2" wood screws, from the bottom of the apron pieces into the table top planks.

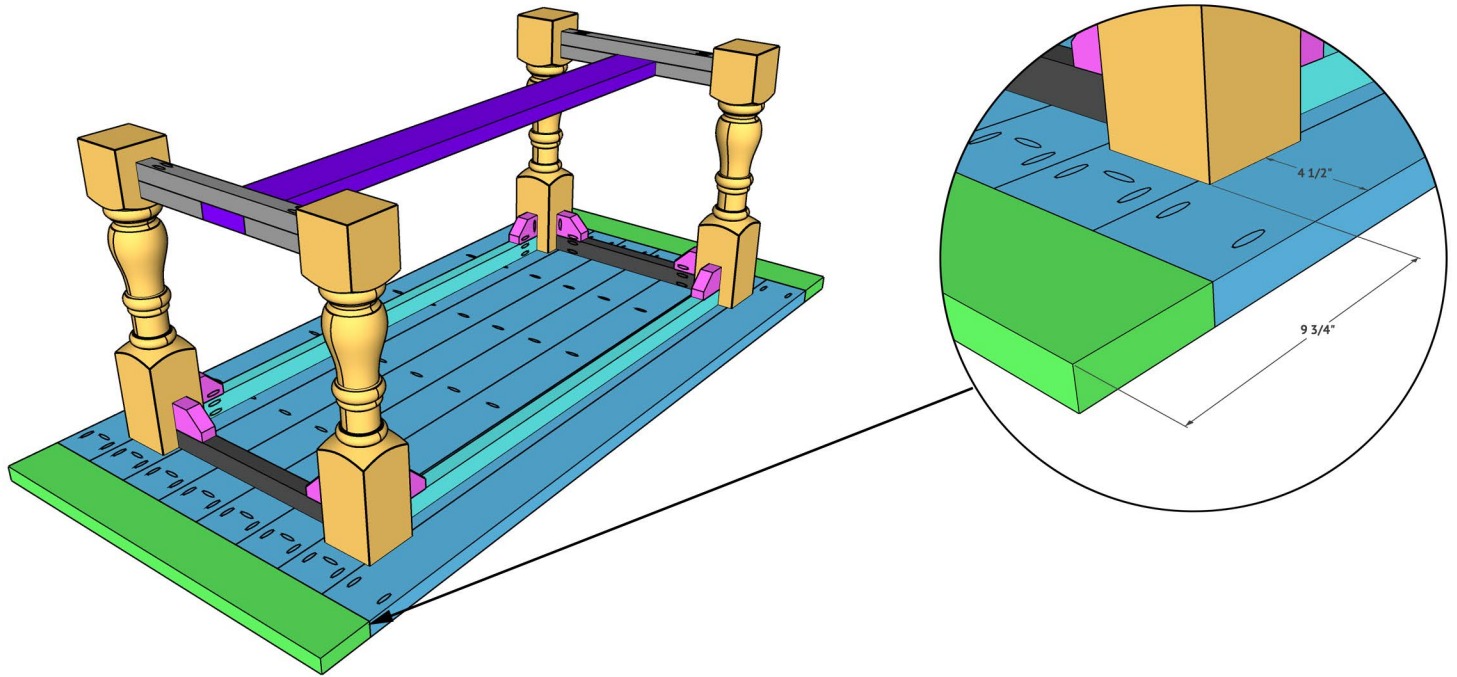

Sand the table down, fill any exposed pocket holes with wood filler and add a finish!

Make sure to share your builds with us on social media and use #shanty2chic so we can share them too!

Happy Building!

